

National Testing Agency

Question Paper Name: Paper I EH 12th Jan 2019 Shift 2
Subject Name: Paper I EH
Creation Date: 2019-01-13 00:46:25
Duration: 180
Total Marks: 360
Display Marks: Yes
Share Answer Key With Delivery Engine: Yes
Actual Answer Key: Yes

Paper I

Group Number : 1
Group Id : 416529123
Group Maximum Duration : 0
Group Minimum Duration : 180
Revisit allowed for view? : No
Revisit allowed for edit? : No
Break time: 0
Group Marks: 360

Physics

Section Id : 416529151
Section Number : 1
Section type : Online
Mandatory or Optional: Mandatory
Number of Questions: 30
Number of Questions to be attempted: 30
Section Marks: 120
Display Number Panel: Yes
Group All Questions: No

Sub-Section Number: 1
Sub-Section Id: 416529160
Question Shuffling Allowed : Yes

Question Number : 1 Question Id : 4165299866 Question Type : MCQ Option Shuffling : Yes Display Question Number : Yes
Single Line Question Option : No Option Orientation : Vertical

Correct Marks : 4 Wrong Marks : 1

Let l , r , c and v represent inductance, resistance, capacitance and voltage,

respectively. The dimension of $\frac{l}{rcv}$ in SI

units will be :

Options :

41652938922. [LTA]

41652938923. [A⁻¹]

41652938924. [LT²]

41652938925. [LA⁻²]

Question Number : 1 Question Id : 4165299866 Question Type : MCQ Option Shuffling : Yes Display Question Number : Yes
Single Line Question Option : No Option Orientation : Vertical

Correct Marks : 4 Wrong Marks : 1

माना l, r, c व v क्रमशः प्रेरकत्व, प्रतिरोध, धारिता व

विभव को दर्शाते हैं। $\frac{l}{rcv}$ की विमा SI मात्रकों में

होगी :

Options :

41652938922. [LTA]

41652938923. [A⁻¹]

41652938924. [LT²]

41652938925. [LA⁻²]

Question Number : 2 Question Id : 4165299867 Question Type : MCQ Option Shuffling : Yes Display Question Number : Yes
Single Line Question Option : No Option Orientation : Vertical

Correct Marks : 4 Wrong Marks : 1

Two particles A, B are moving on two concentric circles of radii R_1 and R_2 with equal angular speed ω . At $t=0$, their positions and direction of motion are shown in the figure :

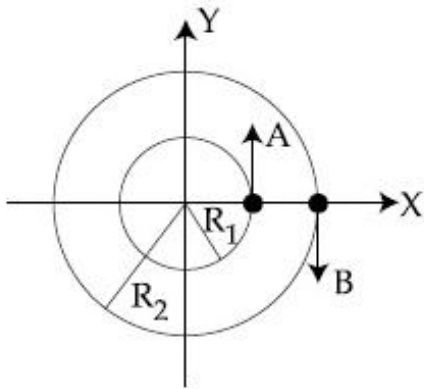

The relative velocity $\vec{v}_A - \vec{v}_B$ at $t = \frac{\pi}{2\omega}$ is

given by :

Options :

41652938926. $\omega(R_1 - R_2)\hat{i}$

41652938927. $\omega(R_2 - R_1)\hat{i}$

41652938928. $-\omega(R_1 + R_2)\hat{i}$

41652938929. $\omega(R_1 + R_2)\hat{i}$

41652938926. $\omega(R_1 + R_2)\hat{i}$

41652938927. $-\omega(R_1 - R_2)\hat{i}$

41652938928. $-\omega(R_1 + R_2)\hat{i}$

Question Number : 2 Question Id : 4165299867 Question Type : MCQ Option Shuffling : Yes Display Question Number : Yes
 Single Line Question Option : No Option Orientation : Vertical
 Correct Marks : 4 Wrong Marks : 1

दो कण, A एवं B, बराबर कोणीय वेग ω से R_1 एवं R_2 त्रिज्या के दो समकेन्द्रित वृत्तों पर चल रहे हैं। समय $t=0$ पर उनकी गति की दिशाएँ एवं स्थितियों को चित्र में दिखाया गया है।

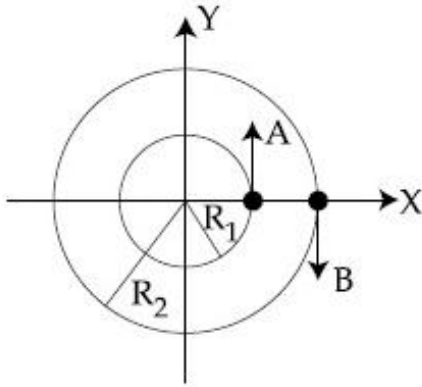

$t = \frac{\pi}{2\omega}$ पर सापेक्ष वेग $\vec{v}_A - \vec{v}_B$ होगा :

Options :

41652938926. $\omega(R_1 - R_2)\hat{i}$

41652938927. $\omega(R_2 - R_1)\hat{i}$

41652938928. $-\omega(R_1 + R_2)\hat{i}$

41652938929. $\omega(R_1 + R_2)\hat{i}$

Question Number : 3 Question Id : 4165299868 Question Type : MCQ Option Shuffling : Yes Display Question Number : Yes Single Line Question Option : No Option Orientation : Vertical

Correct Marks : 4 Wrong Marks : 1

A block kept on a rough inclined plane, as shown in the figure, remains at rest upto a maximum force 2 N down the inclined plane. The maximum external force up the inclined plane that does not move the block is 10 N. The coefficient of static friction between the block and the plane is :

[Take $g = 10 \text{ m/s}^2$]

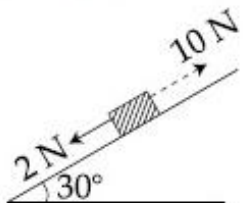

Options :

41652938930. $\frac{1}{2}$

41652938931. $\frac{\sqrt{3}}{4}$

41652938932. $\frac{2}{3}$

41652938933. $\frac{\sqrt{3}}{2}$

Question Number : 3 Question Id : 4165299868 Question Type : MCQ Option Shuffling : Yes Display Question Number : Yes
Single Line Question Option : No Option Orientation : Vertical

Correct Marks : 4 Wrong Marks : 1

चित्रानुसार, एक खुरदरे आनत तल पर, एक गुटका रखा है। यदि गुटके पर समतल के समदिश व नीचे की ओर 2 N मान तक का बल लगाया जाता है तो गुटका स्थिर रहता है। ऐसा बल जब ऊपर की ओर लगाते हैं तो 10 N बल के मान तक गुटका स्थिर रहता है। गुटके व समतल के बीच घर्षण गुणांक का मान होगा :

[$g = 10 \text{ m/s}^2$]

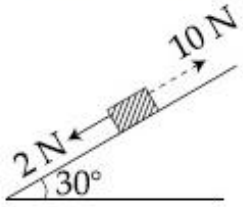

Options :

41652938930. $\frac{1}{2}$

41652938931. $\frac{\sqrt{3}}{4}$

41652938932. $\frac{2}{3}$

41652938933. $\frac{\sqrt{3}}{2}$

Question Number : 4 Question Id : 4165299869 Question Type : MCQ Option Shuffling : Yes Display Question Number : Yes
Single Line Question Option : No Option Orientation : Vertical

Correct Marks : 4 Wrong Marks : 1

An alpha-particle of mass m suffers 1-dimensional elastic collision with a nucleus at rest of unknown mass. It is scattered directly backwards losing, 64% of its initial kinetic energy. The mass of the nucleus is :

Options :

41652938934. 4 m

41652938935. 3.5 m

41652938936. 2 m

41652938937. 1.5 m

Question Number : 4 Question Id : 4165299869 Question Type : MCQ Option Shuffling : Yes Display Question Number : Yes
Single Line Question Option : No Option Orientation : Vertical

Correct Marks : 4 Wrong Marks : 1

एक m द्रव्यमान का अल्फा कण किसी अज्ञात द्रव्यमान के स्थिर नाभिक से एक-विमीय प्रत्यास्थ संघट्ट करके अपनी प्रारंभिक गतिज ऊर्जा का 64% भाग क्षय करके ठीक विपरीत दिशा में प्रकीर्णित हो जाता है। नाभिक का द्रव्यमान होगा :

Options :

41652938934. 4 m

41652938935. 3.5 m

41652938936. 2 m

41652938937. 1.5 m

Question Number : 5 Question Id : 4165299870 Question Type : MCQ Option Shuffling : Yes Display Question Number : Yes
Single Line Question Option : No Option Orientation : Vertical

Correct Marks : 4 Wrong Marks : 1

A particle of mass 20 g is released with an initial velocity 5 m/s along the curve from the point A, as shown in the figure. The point A is at height h from point B. The particle slides along the frictionless surface. When the particle reaches point B, its angular momentum about O will be :

(Take $g = 10 \text{ m/s}^2$)

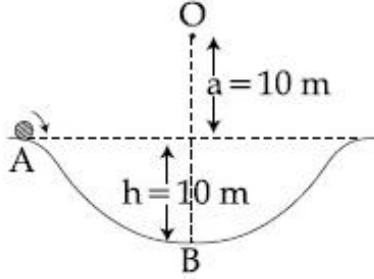

Options :

41652938938. $6 \text{ kg-m}^2/\text{s}$

41652938939. $8 \text{ kg-m}^2/\text{s}$

41652938940. $2 \text{ kg-m}^2/\text{s}$

41652938941. $3 \text{ kg-m}^2/\text{s}$

Question Number : 5 Question Id : 4165299870 Question Type : MCQ Option Shuffling : Yes Display Question Number : Yes Single Line Question Option : No Option Orientation : Vertical

Correct Marks : 4 Wrong Marks : 1

चित्रानुसार 20 g द्रव्यमान के एक कण को 5 m/s वेग के अनुगत आरम्भिक वेग से बिन्दु A से छोड़ा जाता है। बिन्दु A की बिन्दु B से ऊँचाई h है। यह कण घर्षणहीन पृष्ठ पर सरकता है। जब कण बिन्दु B पर पहुँचता है, तो इसका बिन्दु O के सापेक्ष कोणीय संवेग क्या होगा?

(दिया है : $g = 10 \text{ m/s}^2$)

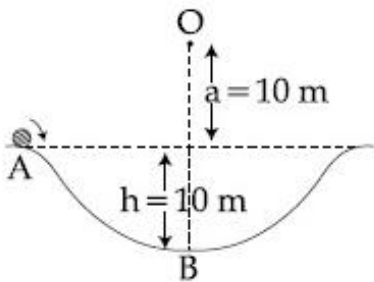

Options :

41652938938. $6 \text{ kg-m}^2/\text{s}$

41652938939. $8 \text{ kg-m}^2/\text{s}$

41652938940. $2 \text{ kg-m}^2/\text{s}$

41652938941. $3 \text{ kg-m}^2/\text{s}$

Question Number : 6 Question Id : 4165299871 Question Type : MCQ Option Shuffling : Yes Display Question Number : Yes
Single Line Question Option : No Option Orientation : Vertical

Correct Marks : 4 Wrong Marks : 1

The moment of inertia of a solid sphere, about an axis parallel to its diameter and at a distance of x from it, is ' $I(x)$ '. Which one of the graphs represents the variation of $I(x)$ with x correctly ?

Options :

41652938942.

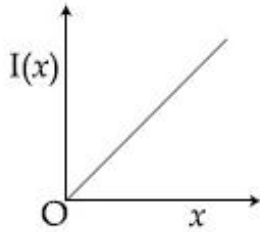

41652938943.

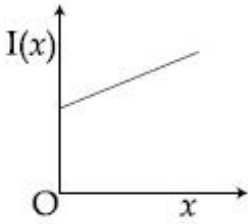

41652938944.

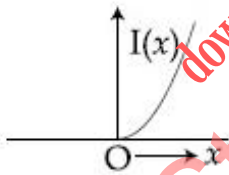

41652938945.

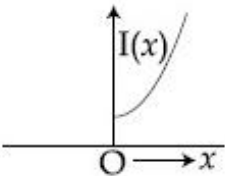

Question Number : 6 Question Id : 4165299871 Question Type : MCQ Option Shuffling : Yes Display Question Number : Yes
Single Line Question Option : No Option Orientation : Vertical

Correct Marks : 4 Wrong Marks : 1

एक ठोस गोले का जड़त्व आघूर्ण, एक अक्ष के सापेक्ष, जो उसके व्यास के समान्तर तथा उससे x दूरी पर है, $I(x)$ है। निम्न में से कौन सा ग्राफ $I(x)$ का x के साथ परिवर्तन को सही दर्शाता है?

Options :

41652938942.

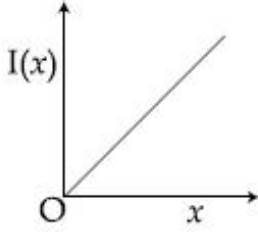

41652938943.

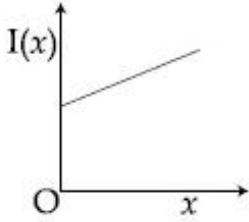

41652938944.

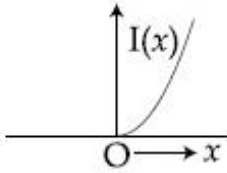

41652938945.

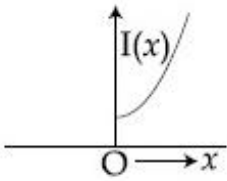

Question Number : 7 Question Id : 4165299872 Question Type : MCQ Option Shuffling : Yes Display Question Number : Yes
Single Line Question Option : No Option Orientation : Vertical

Correct Marks : 4 Wrong Marks : 1

Two satellites, A and B, have masses m and $2m$ respectively. A is in a circular orbit of radius R , and B is in a circular orbit of radius $2R$ around the earth. The ratio of their kinetic energies, T_A/T_B , is :

Options :

41652938946. 2

41652938947. $\frac{1}{2}$

41652938948. 1

$$\sqrt{\frac{1}{2}}$$

41652938949.

Question Number : 7 Question Id : 4165299872 Question Type : MCQ Option Shuffling : Yes Display Question Number : Yes
Single Line Question Option : No Option Orientation : Vertical

Correct Marks : 4 Wrong Marks : 1

दो उपग्रहों, A और B, के द्रव्यमान क्रमशः m एवं $2m$ हैं। पृथ्वी के परितः A, त्रिज्या R के वृत्ताकार कक्ष में तथा, B त्रिज्या $2R$ के वृत्ताकार कक्षा में चल रहे हैं। उपग्रहों की गतिज ऊर्जाओं के अनुपात, T_A/T_B का मान होगा :

Options :

41652938946. 2

41652938947. $\frac{1}{2}$

41652938948. 1

41652938949. $\sqrt{\frac{1}{2}}$

Question Number : 8 Question Id : 4165299873 Question Type : MCQ Option Shuffling : Yes Display Question Number : Yes
Single Line Question Option : No Option Orientation : Vertical

Correct Marks : 4 Wrong Marks : 1

A long cylindrical vessel is half filled with a liquid. When the vessel is rotated about its own vertical axis, the liquid rises up near the wall. If the radius of vessel is 5 cm and its rotational speed is 2 rotations per second, then the difference in the heights between the centre and the sides, in cm, will be :

Options :

41652938950. 0.4

41652938951. 0.1

41652938952. 2.0

41652938953. 1.2

Question Number : 8 Question Id : 4165299873 Question Type : MCQ Option Shuffling : Yes Display Question Number : Yes
Single Line Question Option : No Option Orientation : Vertical

Correct Marks : 4 Wrong Marks : 1

एक लंबे बेलनाकार पात्र द्रव से आधा भरा हुआ है। जब पात्र को अपनी ऊर्ध्व अक्ष के संगत घुमाते हैं तो, द्रव पात्र की दीवार के समीप ऊपर उठता है। यदि पात्र की त्रिज्या 5 cm तथा इसकी घूर्णन गति 2 चक्कर प्रति सेकेण्ड है, तो पात्र के मध्य तथा किनारे पर द्रव की ऊँचाई में अन्तर का मान cm में, होगा :

Options :

41652938950. 0.4

41652938951. 0.1

41652938952. 2.0

41652938953. 1.2

Question Number : 9 Question Id : 4165299874 Question Type : MCQ Option Shuffling : Yes Display Question Number : Yes Single Line Question Option : No Option Orientation : Vertical

Correct Marks : 4 Wrong Marks : 1

A soap bubble, blown by a mechanical pump at the mouth of a tube, increases in volume, with time, at a constant rate. The graph that correctly depicts the time dependence of pressure inside the bubble is given by :

Options :

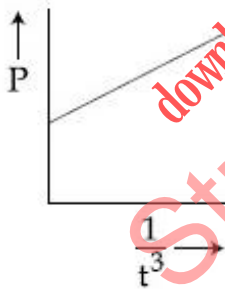

41652938954.

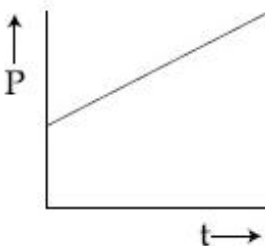

41652938955.

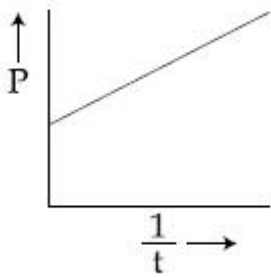

41652938956.

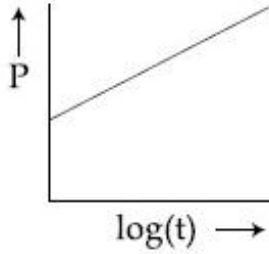

41652938957.

Question Number : 9 Question Id : 4165299874 Question Type : MCQ Option Shuffling : Yes Display Question Number : Yes
 Single Line Question Option : No Option Orientation : Vertical
 Correct Marks : 4 Wrong Marks : 1

एक नली के मुख पर एक यांत्रिक पम्प से फुलाकर एक साबुन के बुलबुले का आयतन, समय के साथ, एक स्थिर दर से बढ़ता है। निम्न ग्राफों में कौन, बुलबुले के अन्दर के दाब का समय के साथ बदलाव को, सही चित्रित करता है?

Options :

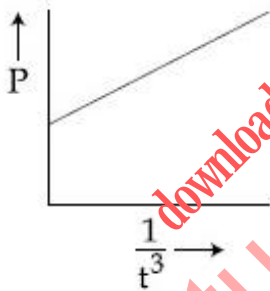

41652938954.

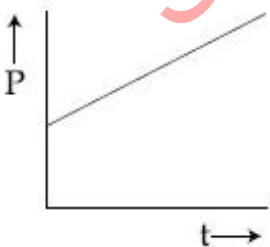

41652938955.

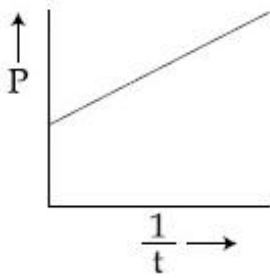

41652938956.

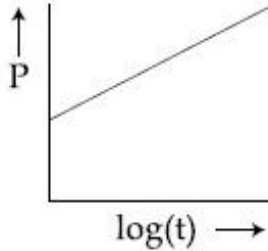

41652938957.

Question Number : 10 Question Id : 4165299875 Question Type : MCQ Option Shuffling : Yes Display Question Number : Yes Single Line Question Option : No Option Orientation : Vertical

Correct Marks : 4 Wrong Marks : 1

A vertical closed cylinder is separated into two parts by a frictionless piston of mass m and of negligible thickness. The piston is free to move along the length of the cylinder. The length of the cylinder above the piston is l_1 , and that below the piston is l_2 , such that $l_1 > l_2$. Each part of the cylinder contains n moles of an ideal gas at equal temperature T . If the piston is stationary, its mass, m , will be given by :

(R is universal gas constant and g is the acceleration due to gravity)

Options :

41652938958.
$$\frac{nRT}{g} \left[\frac{1}{l_2} + \frac{1}{l_1} \right]$$

41652938959.
$$\frac{nRT}{g} \left[\frac{l_1 - l_2}{l_1 l_2} \right]$$

41652938960.
$$\frac{RT}{g} \left[\frac{2l_1 + l_2}{l_1 l_2} \right]$$

41652938961.
$$\frac{RT}{ng} \left[\frac{l_1 - 3l_2}{l_1 l_2} \right]$$

Correct Marks : 4 Wrong Marks : 1

गैस से भरे हुए एक बन्द ऊर्ध्वाधर बेलनाकार बर्तन को, एक घर्षणहीन एवं नगण्य मोटाई के, m द्रव्यमान के पिस्टन से दो भागों में बाँटते हैं। पिस्टन बेलन की लम्बाई के अनुदिश चलने को स्वतंत्र है। पिस्टन के ऊपर बेलन की लम्बाई l_1 और पिस्टन के नीचे की लम्बाई l_2 इस प्रकार है कि, $l_1 > l_2$ है। बेलन के प्रत्येक भाग में एक आदर्श गैस के n मोल समान तापमान T पर हैं। यदि पिस्टन स्थायी है तो इसके द्रव्यमान m का मान होगा :

(R , सार्वत्रिक गैस नियतांक तथा g , गुरुत्वीय त्वरण है)

Options :

41652938958. $\frac{nRT}{g} \left[\frac{1}{l_2} + \frac{1}{l_1} \right]$

41652938959. $\frac{nRT}{g} \left[\frac{l_1 - l_2}{l_1 l_2} \right]$

41652938960. $\frac{RT}{g} \left[\frac{2l_1 + l_2}{l_1 l_2} \right]$

41652938961. $\frac{RT}{ng} \left[\frac{l_1 - 3l_2}{l_1 l_2} \right]$

Question Number : 11 Question Id : 4165299876 Question Type : MCQ Option Shuffling : Yes Display Question Number : Yes
Single Line Question Option : No Option Orientation : Vertical

Correct Marks : 4 Wrong Marks : 1

An ideal gas is enclosed in a cylinder at pressure of 2 atm and temperature, 300 K. The mean time between two successive collisions is 6×10^{-8} s. If the pressure is doubled and temperature is increased to 500 K, the mean time between two successive collisions will be close to :

Options :

41652938962. 3×10^{-6} s

41652938963. 2×10^{-7} s

41652938964. 0.5×10^{-8} s

41652938965. 4×10^{-8} s

Question Number : 11 Question Id : 4165299876 Question Type : MCQ Option Shuffling : Yes Display Question Number : Yes
Single Line Question Option : No Option Orientation : Vertical

Correct Marks : 4 Wrong Marks : 1

एक बन्द सिलेण्डर में एक आदर्श गैस 2 atm दाब, एवं 300 K तापमान पर हैं। दो क्रमागत संघट्टों के बीच औसत समय 6×10^{-8} s है। यदि दाब को दोगुना तथा तापमान को 500 K कर दे, तो दो क्रमागत संघट्टों के बीच औसत समय का सन्निकट मान होगा :

Options :

41652938962. 3×10^{-6} s

41652938963. 2×10^{-7} s

41652938964. 0.5×10^{-8} s

41652938965. 4×10^{-8} s

Question Number : 12 Question Id : 4165299877 Question Type : MCQ Option Shuffling : Yes Display Question Number : Yes
Single Line Question Option : No Option Orientation : Vertical

Correct Marks : 4 Wrong Marks : 1

A simple harmonic motion is represented by :

$$y = 5(\sin 3\pi t + \sqrt{3} \cos 3\pi t) \text{ cm}$$

The amplitude and time period of the motion are :

Options :

41652938966. 5 cm, $\frac{3}{2}$ s

41652938967. 5 cm, $\frac{2}{3}$ s

41652938968. 10 cm, $\frac{3}{2}$ s

41652938969. 10 cm, $\frac{2}{3}$ s

Question Number : 12 Question Id : 4165299877 Question Type : MCQ Option Shuffling : Yes Display Question Number : Yes
Single Line Question Option : No Option Orientation : Vertical

Correct Marks : 4 Wrong Marks : 1

एक सरल आवर्त गति को निम्न समीकरण से दिखाया जाता है :

$$y = 5(\sin 3\pi t + \sqrt{3} \cos 3\pi t) \text{ cm}$$

गति के आयाम तथा आवर्तकाल होंगे :

Options :

41652938966. $5 \text{ cm}, \frac{3}{2} \text{ s}$

41652938967. $5 \text{ cm}, \frac{2}{3} \text{ s}$

41652938968. $10 \text{ cm}, \frac{3}{2} \text{ s}$

41652938969. $10 \text{ cm}, \frac{2}{3} \text{ s}$

Question Number : 13 Question Id : 4165299878 Question Type : MCQ Option Shuffling : Yes Display Question Number : Yes
Single Line Question Option : No Option Orientation : Vertical

Correct Marks : 4 Wrong Marks : 1

A resonance tube is old and has jagged end. It is still used in the laboratory to determine velocity of sound in air. A tuning fork of frequency 512 Hz produces first resonance when the tube is filled with water to a mark 11 cm below a reference mark, near the open end of the tube. The experiment is repeated with another fork of frequency 256 Hz which produces first resonance when water reaches a mark 27 cm below the reference mark. The velocity of sound in air, obtained in the experiment, is close to :

Options :

41652938970. 328 ms^{-1}

41652938971. 335 ms^{-1}

41652938972. 322 ms^{-1}

41652938973. 341 ms^{-1}

Question Number : 13 Question Id : 4165299878 Question Type : MCQ Option Shuffling : Yes Display Question Number : Yes
Single Line Question Option : No Option Orientation : Vertical

Correct Marks : 4 Wrong Marks : 1

एक अनुनादी नली पुरानी है तथा उसके किनारे खराब हैं। इसको तभी भी प्रयोगशाला में, वायु में ध्वनि की चाल ज्ञात करने के लिये, उपयोग करते हैं। नली के खुले सिरे के समीप निर्देशक चिन्ह से 11 cm नीचे एक चिन्ह तक नली में जब पानी भर देते हैं, तो 512 Hz आवृत्ति का एक स्वरित्र द्विभुज प्रथम अनुनाद उत्पन्न करता है। यह प्रयोग दूसरे 256 Hz वाले स्वरित्र द्विभुज के साथ दोहराते हैं तो, प्रथम अनुनाद निर्देशक चिन्ह से 27 cm नीचे उत्पन्न हो जाता है। प्रयोग में पायी गयी ध्वनि की वायु में सन्निकट चाल होगी :

Options :

41652938970. 328 ms^{-1}

41652938971. 335 ms^{-1}

41652938972. 322 ms^{-1}

41652938973. 341 ms^{-1}

Question Number : 14 Question Id : 4165299879 Question Type : MCQ Option Shuffling : Yes Display Question Number : Yes
Single Line Question Option : No Option Orientation : Vertical

Correct Marks : 4 Wrong Marks : 1

A parallel plate capacitor with plates of area 1 m^2 each, are at a separation of 0.1 m. If the electric field between the plates is 100 N/C, the magnitude of charge on each plate is :

(Take $\epsilon_0 = 8.85 \times 10^{-12} \frac{\text{C}^2}{\text{N-m}^2}$)

Options :

41652938974. $6.85 \times 10^{-10} \text{ C}$

41652938975. $7.85 \times 10^{-10} \text{ C}$

41652938976. $8.85 \times 10^{-10} \text{ C}$

41652938977. $9.85 \times 10^{-10} \text{ C}$

Question Number : 14 Question Id : 4165299879 Question Type : MCQ Option Shuffling : Yes Display Question Number : Yes
Single Line Question Option : No Option Orientation : Vertical

Correct Marks : 4 Wrong Marks : 1

एक समान्तर प्लेट संधारित्र की प्रत्येक प्लेट का क्षेत्रफल 1 m^2 तथा प्लेटों के बीच की दूरी 0.1 m है। यदि प्लेटों के बीच विद्युत क्षेत्र 100 N/C हो तो, संधारित्र की प्रत्येक प्लेट पर आवेश का परिमाण है,

$$(\epsilon_0 = 8.85 \times 10^{-12} \frac{\text{C}^2}{\text{N-m}^2} \text{ लीजिये})$$

Options :

41652938974. $6.85 \times 10^{-10} \text{ C}$

41652938975. $7.85 \times 10^{-10} \text{ C}$

41652938976. $8.85 \times 10^{-10} \text{ C}$

41652938977. $9.85 \times 10^{-10} \text{ C}$

Question Number : 15 Question Id : 4165299880 Question Type : MCQ Option Shuffling : Yes Display Question Number : Yes Single Line Question Option : No Option Orientation : Vertical

Correct Marks : 4 Wrong Marks : 1

In the circuit shown, find C if the effective capacitance of the whole circuit is to be $0.5 \mu\text{F}$. All values in the circuit are in μF .

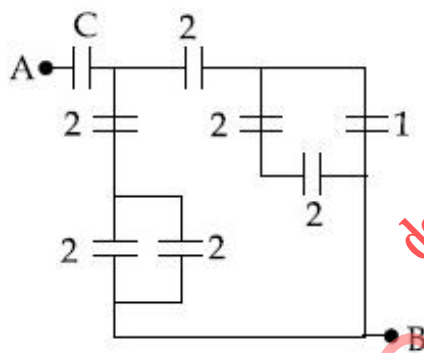

Options :

41652938978. $\frac{7}{10} \mu\text{F}$

41652938979. $4 \mu\text{F}$

41652938980. $\frac{7}{11} \mu\text{F}$

41652938981. $\frac{6}{5} \mu\text{F}$

Question Number : 15 Question Id : 4165299880 Question Type : MCQ Option Shuffling : Yes Display Question Number : Yes Single Line Question Option : No Option Orientation : Vertical

Correct Marks : 4 Wrong Marks : 1

दिखाये गये परिपथ में, यदि पूरे परिपथ की प्रभावी धारिता $0.5 \mu\text{F}$ है तो C का मान क्या होगा? परिपथ में सभी धारिताएं μF में हैं।

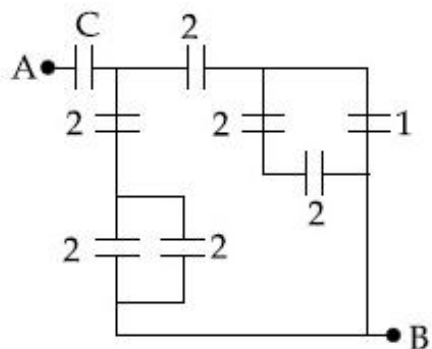

Options :

41652938978. $\frac{7}{10} \mu\text{F}$

41652938979. $4 \mu\text{F}$

41652938980. $\frac{7}{11} \mu\text{F}$

41652938981. $\frac{6}{5} \mu\text{F}$

Question Number : 16 Question Id : 4165299881 Question Type : MCQ Option Shuffling : Yes Display Question Number : Yes Single Line Question Option : No Option Orientation : Vertical

Correct Marks : 4 Wrong Marks : 1

In the given circuit diagram, the currents, $I_1 = -0.3 \text{ A}$, $I_4 = 0.8 \text{ A}$ and $I_5 = 0.4 \text{ A}$, are flowing as shown. The currents I_2 , I_3 and I_6 , respectively, are :

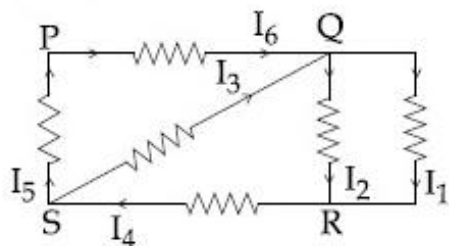

Options :

41652938982. $1.1 \text{ A}, -0.4 \text{ A}, 0.4 \text{ A}$

41652938983. $-0.4 \text{ A}, 0.4 \text{ A}, 1.1 \text{ A}$

41652938984. 1.1 A, 0.4 A, 0.4 A

41652938985. 0.4 A, 1.1 A, 0.4 A

Question Number : 16 Question Id : 4165299881 Question Type : MCQ Option Shuffling : Yes Display Question Number : Yes
Single Line Question Option : No Option Orientation : Vertical

Correct Marks : 4 Wrong Marks : 1

दिखाये गये परिपथ में धारायें $I_1 = -0.3$ A, $I_4 = 0.8$ A और $I_5 = 0.4$ A प्रवाहित हो रही हैं। धाराओं, I_2 , I_3 तथा I_6 के मान क्रमशः होंगे :

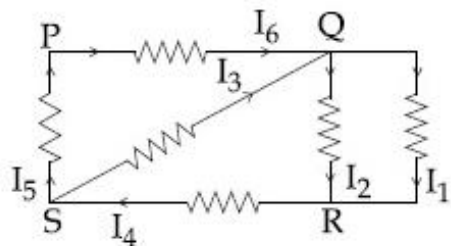

Options :

41652938982. 1.1 A, -0.4 A, 0.4 A

41652938983. -0.4 A, 0.4 A, 1.1 A

41652938984. 1.1 A, 0.4 A, 0.4 A

41652938985. 0.4 A, 1.1 A, 0.4 A

Question Number : 17 Question Id : 4165299882 Question Type : MCQ Option Shuffling : Yes Display Question Number : Yes
Single Line Question Option : No Option Orientation : Vertical

Correct Marks : 4 Wrong Marks : 1

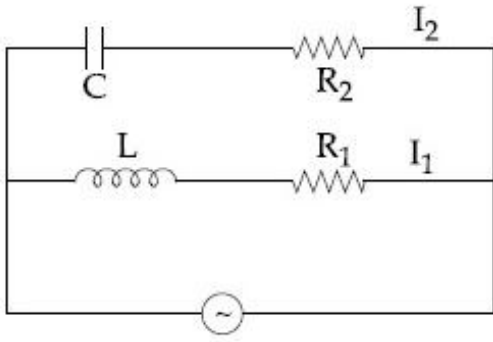

In the above circuit, $C = \frac{\sqrt{3}}{2} \mu\text{F}$, $R_2 = 20 \Omega$,

$L = \frac{\sqrt{3}}{10} \text{ H}$ and $R_1 = 10 \Omega$. Current in

L - R_1 path is I_1 and in C - R_2 path it is I_2 . The voltage of A.C source is given by,

$V = 200\sqrt{2}\sin(100t)$ volts. The phase difference between I_1 and I_2 is :

Options :

41652938986. 0°

41652938987. 60°

41652938988. 90°

41652938989. 30°

Question Number : 17 Question Id : 4165293882 Question Type : MCQ Option Shuffling : Yes Display Question Number : Yes
Single Line Question Option : No Option Orientation : Vertical
Correct Marks : 4 Wrong Marks : 1

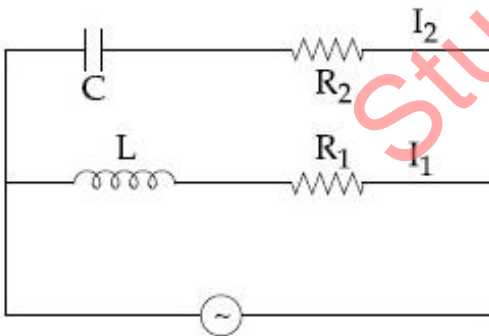

दिखाये गये परिपथ में $C = \frac{\sqrt{3}}{2} \mu\text{F}$, $R_2 = 20 \Omega$,

$L = \frac{\sqrt{3}}{10} \text{ H}$ तथा $R_1 = 10 \Omega$ है। L - R_1 पथ में धारा

I_1 , और C - R_2 पथ में धारा I_2 है। AC स्रोत की वोल्टता,

$V = 200\sqrt{2}\sin(100t)$ वोल्ट सूत्र द्वारा दी गयी है।

I_1 तथा I_2 के बीच कलान्तर है :

Options :

41652938986. 0°

41652938987. 60°

41652938988. 90°

41652938989. 30°

Question Number : 18 Question Id : 4165299883 Question Type : MCQ Option Shuffling : Yes Display Question Number : Yes
Single Line Question Option : No Option Orientation : Vertical

Correct Marks : 4 Wrong Marks : 1

A galvanometer, whose resistance is 50 ohm, has 25 divisions in it. When a current of 4×10^{-4} A passes through it, its needle (pointer) deflects by one division. To use this galvanometer as a voltmeter of range 2.5 V, it should be connected to a resistance of :

Options :

41652938990. 6250 ohm

41652938991. 6200 ohm

41652938992. 250 ohm

41652938993. 200 ohm

Question Number : 18 Question Id : 4165299883 Question Type : MCQ Option Shuffling : Yes Display Question Number : Yes
Single Line Question Option : No Option Orientation : Vertical

Correct Marks : 4 Wrong Marks : 1

50Ω प्रतिरोध वाले एक गैल्वेनोमीटर में 25 भाग हैं। जब इसमें 4×10^{-4} A की धारा प्रवाहित करते हैं तो इसकी सुई द्वारा 1 भाग का विक्षेप होता है। इस गैल्वेनोमीटर को 2.5 V परास वाले वोल्टमीटर के रूप में उपयोग करने के लिये, इसके साथ कौन-सा प्रतिरोध जोड़ना पड़ेगा ?

Options :

41652938990. 6250 ohm

41652938991. 6200 ohm

41652938992. 250 ohm

41652938993. 200 ohm

Question Number : 19 Question Id : 4165299884 Question Type : MCQ Option Shuffling : Yes Display Question Number : Yes
Single Line Question Option : No Option Orientation : Vertical

Correct Marks : 4 Wrong Marks : 1

A paramagnetic material has 10^{28} atoms/ m^3 . Its magnetic susceptibility at temperature 350 K is 2.8×10^{-4} . Its susceptibility at 300 K is :

Options :

41652938994. 3.726×10^{-4}

41652938995. 3.267×10^{-4}

41652938996. 2.672×10^{-4}

41652938997. 3.672×10^{-4}

Question Number : 19 Question Id : 4165299884 Question Type : MCQ Option Shuffling : Yes Display Question Number : Yes
Single Line Question Option : No Option Orientation : Vertical

Correct Marks : 4 Wrong Marks : 1

एक अनुचुम्बकीय पदार्थ में 10^{28} परमाणु /मी³ हैं। पदार्थ की 350 K तापमान पर, चुम्बकीय प्रवृत्ति 2.8×10^{-4} है। 300 K पर, उसकी चुम्बकीय प्रवृत्ति होगी :

Options :

41652938994. 3.726×10^{-4}

41652938995. 3.267×10^{-4}

41652938996. 2.672×10^{-4}

41652938997. 3.672×10^{-4}

Question Number : 20 Question Id : 4165299885 Question Type : MCQ Option Shuffling : Yes Display Question Number : Yes
Single Line Question Option : No Option Orientation : Vertical

Correct Marks : 4 Wrong Marks : 1

A 10 m long horizontal wire extends from North East to South West. It is falling with a speed of 5.0 ms^{-1} , at right angles to the horizontal component of the earth's magnetic field, of $0.3 \times 10^{-4} \text{ Wb/m}^2$. The value of the induced emf in wire is :

Options :

41652938998. $1.1 \times 10^{-3} \text{ V}$

41652938999. $2.5 \times 10^{-3} \text{ V}$

41652939000. $1.5 \times 10^{-3} \text{ V}$

41652939001. $0.3 \times 10^{-3} \text{ V}$

Question Number : 20 Question Id : 4165299885 Question Type : MCQ Option Shuffling : Yes Display Question Number : Yes
Single Line Question Option : No Option Orientation : Vertical

Correct Marks : 4 Wrong Marks : 1

एक 10 मीटर का क्षैतिज तार, उत्तर-पूर्व से दक्षिण-पश्चिम दिशा में विस्तृत है, और 5.0 ms^{-1} की चाल से पृथ्वी के चुम्बकीय क्षेत्र के क्षैतिज घटक, $0.3 \times 10^{-4} \text{ Wb/m}^2$, के लम्बवत् गिर रहा है। तार में प्रेरित विद्युत वाहक बल का मान होगा :

Options :

41652938998. $1.1 \times 10^{-3} \text{ V}$

41652938999. $2.5 \times 10^{-3} \text{ V}$

41652939000. $1.5 \times 10^{-3} \text{ V}$

41652939001. $0.3 \times 10^{-3} \text{ V}$

Question Number : 21 Question Id : 4165299886 Question Type : MCQ Option Shuffling : Yes Display Question Number : Yes
Single Line Question Option : No Option Orientation : Vertical

Correct Marks : 4 Wrong Marks : 1

The mean intensity of radiation on the surface of the Sun is about 10^8 W/m^2 . The rms value of the corresponding magnetic field is closest to :

Options :

41652939002. 10^{-4} T

41652939003. 10^{-2} T

41652939004. 1 T

41652939005. 10^2 T

Question Number : 21 Question Id : 4165299886 Question Type : MCQ Option Shuffling : Yes Display Question Number : Yes
Single Line Question Option : No Option Orientation : Vertical

Correct Marks : 4 Wrong Marks : 1

सूर्य की सतह पर विकिरण की औसत तीव्रता लगभग 10^8 W/m^2 है। तो संगत चुम्बकीय क्षेत्र का निकटतम वर्ग-माध्य-मूल मान होगा :

Options :

41652939002. 10^{-4} T

41652939003. 10^{-2} T

41652939004. 1 T

41652939005. 10^2 T

Question Number : 22 Question Id : 4165299887 Question Type : MCQ Option Shuffling : Yes Display Question Number : Yes
Single Line Question Option : No Option Orientation : Vertical

Correct Marks : 4 Wrong Marks : 1

A plano-convex lens (focal length f_2 , refractive index μ_2 , radius of curvature R) fits exactly into a plano-concave lens (focal length f_1 , refractive index μ_1 , radius of curvature R). Their plane surfaces are parallel to each other. Then, the focal length of the combination will be :

Options :

41652939006. $f_1 + f_2$

41652939007. $f_1 - f_2$

41652939008. $\frac{2f_1 f_2}{f_1 + f_2}$

41652939009. $\frac{R}{\mu_2 - \mu_1}$

Question Number : 22 Question Id : 4165299887 Question Type : MCQ Option Shuffling : Yes Display Question Number : Yes
Single Line Question Option : No Option Orientation : Vertical

Correct Marks : 4 Wrong Marks : 1

एक समतल-उत्तल लेंस (फोकस दूरी f_2 , अपवर्तनांक μ_2 , वक्रता त्रिज्या R) एक समतल-अवतल लेंस (फोकस दूरी f_1 , अपवर्तनांक μ_1 , वक्रता त्रिज्या R) में ठीक बैठ जाता है। उनके समतल पृष्ठ एक दूसरे के समान्तर हैं। इस संयोजन की फोकस दूरी होगी :

Options :

41652939006. $f_1 + f_2$

41652939007. $f_1 - f_2$

41652939008. $\frac{2f_1 f_2}{f_1 + f_2}$

41652939009. $\frac{R}{\mu_2 - \mu_1}$

Question Number : 23 Question Id : 4165299888 Question Type : MCQ Option Shuffling : Yes Display Question Number : Yes
Single Line Question Option : No Option Orientation : Vertical

Correct Marks : 4 Wrong Marks : 1

Formation of real image using a biconvex lens is shown below :

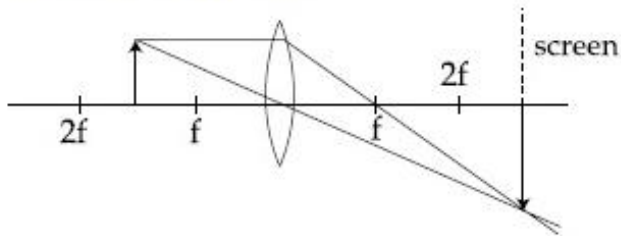

If the whole set up is immersed in water without disturbing the object and the screen positions, what will one observe on the screen ?

Options :

41652939010. No change

41652939011. Magnified image

41652939012. Image disappears

41652939013. Erect real image

Question Number : 23 Question Id : 4165299888 Question Type : MCQ Option Shuffling : Yes Display Question Number : Yes
Single Line Question Option : No Option Orientation : Vertical

Correct Marks : 4 Wrong Marks : 1

एक उभयोत्तल लेंस से एक वास्तविक प्रतिबिम्ब के बनने का चित्र में दर्शाया गया है :

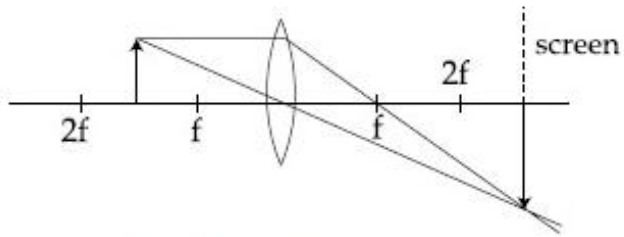

वस्तु तथा पर्दे की स्थिति को बिना विचलित किये इस संपूर्ण संयोजन को यदि पानी में डुबा दिया जाये तो, पर्दे पर क्या दिखेगा ?

Options :

41652939010. कोई बदलाव नहीं

41652939011. आवर्धित प्रतिबिम्ब

41652939012. प्रतिबिम्ब लुप्त हो जायेगा

41652939013. ऊर्ध्व (erect) वास्तविक प्रतिबिम्ब

Question Number : 24 Question Id : 4165299889 Question Type : MCQ Option Shuffling : Yes Display Question Number : Yes Single Line Question Option : No Option Orientation : Vertical

Correct Marks : 4 Wrong Marks : 1

When a certain photosensitive surface is illuminated with monochromatic light of frequency ν , the stopping potential for the photo current is $-V_0/2$. When the surface is illuminated by monochromatic light of frequency $\nu/2$, the stopping potential is $-V_0$. The threshold frequency for photoelectric emission is :

Options :

41652939014. 2ν

41652939015. $\frac{5\nu}{3}$

41652939016. $\frac{4}{3}\nu$

41652939017. $\frac{3\nu}{2}$

Question Number : 24 Question Id : 4165299889 Question Type : MCQ Option Shuffling : Yes Display Question Number : Yes
Single Line Question Option : No Option Orientation : Vertical

Correct Marks : 4 Wrong Marks : 1

जब कोई प्रकाश संवेदी सतह ν आवृत्ति के एक वर्णीय प्रकाश द्वारा प्रकाशित की जाती है तो प्रकाश वैद्युत धारा का निरोधी विभव $-V_0/2$ होता है। जब वही सतह $\nu/2$ आवृत्ति के एकवर्णी प्रकाश द्वारा प्रकाशित की जाती है तो निरोधी विभव $-V_0$ पाया जाता है। प्रकाश-वैद्युत उत्सर्जन की देहली आवृत्ति होगी :

Options :

41652939014. 2ν

41652939015. $\frac{5\nu}{3}$

41652939016. $\frac{4}{3}\nu$

41652939017. $\frac{3\nu}{2}$

Question Number : 25 Question Id : 4165299890 Question Type : MCQ Option Shuffling : Yes Display Question Number : Yes
Single Line Question Option : No Option Orientation : Vertical

Correct Marks : 4 Wrong Marks : 1

In a Frank-Hertz experiment, an electron of energy 5.6 eV passes through mercury vapour and emerges with an energy 0.7 eV. The minimum wavelength of photons emitted by mercury atoms is close to :

Options :

41652939018. 220 nm

41652939019. 2020 nm

41652939020. 1700 nm

41652939021. 250 nm

Question Number : 25 Question Id : 4165299890 Question Type : MCQ Option Shuffling : Yes Display Question Number : Yes
Single Line Question Option : No Option Orientation : Vertical

Correct Marks : 4 Wrong Marks : 1

एक फ्रैन्क-हर्ट्ज प्रयोग के दौरान, 5.6 eV ऊर्जा का एक इलेक्ट्रॉन पारे के वाष्प से गुजर कर 0.7 eV की ऊर्जा के साथ बाहर निकलता है। पारे के परमाणु द्वारा उत्सर्जित फोटॉन की न्यूनतम तरंगदैर्घ्य का सन्निकट मान होगा :

Options :

41652939018. 220 nm
41652939019. 2020 nm
41652939020. 1700 nm
41652939021. 250 nm

Question Number : 26 Question Id : 4165299891 Question Type : MCQ Option Shuffling : Yes Display Question Number : Yes
Single Line Question Option : No Option Orientation : Vertical

Correct Marks : 4 Wrong Marks : 1

In a radioactive decay chain, the initial nucleus is ${}_{90}^{232}\text{Th}$. At the end there are 6 α -particles and 4 β -particles which are emitted. If the end nucleus is ${}_{Z}^AX$, A and Z are given by :

Options :

41652939022. A = 202 ; Z = 80
41652939023. A = 208 ; Z = 80
41652939024. A = 208 ; Z = 80
41652939025. A = 200 ; Z = 81

Question Number : 26 Question Id : 4165299891 Question Type : MCQ Option Shuffling : Yes Display Question Number : Yes
Single Line Question Option : No Option Orientation : Vertical

Correct Marks : 4 Wrong Marks : 1

किसी एक रेडियो-एक्टिव क्षय श्रृंखला में आरंभिक नाभिक ${}_{90}^{232}\text{Th}$ है। अंत में कुल 6 α -कण एवं 4 β -कण उत्सर्जित हुए हैं। अन्त नाभिक ${}_{Z}^AX$ है तो, A और Z के मान होंगे :

Options :

41652939022. $A = 202 ; Z = 80$

41652939023. $A = 208 ; Z = 82$

41652939024. $A = 208 ; Z = 80$

41652939025. $A = 200 ; Z = 81$

Question Number : 27 Question Id : 4165299892 Question Type : MCQ Option Shuffling : Yes Display Question Number : Yes
Single Line Question Option : No Option Orientation : Vertical

Correct Marks : 4 Wrong Marks : 1

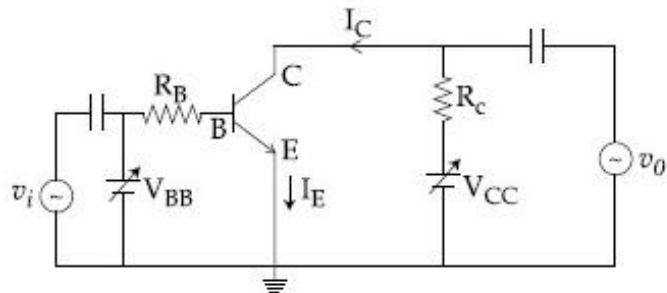

In the figure, given that V_{BB} supply can vary from 0 to 5.0 V, $V_{CC} = 5$ V, $\beta_{dc} = 200$, $R_B = 100$ k Ω , $R_C = 1$ k Ω and $V_{BE} = 1.0$ V, The minimum base current and the input voltage at which the transistor will go to saturation, will be, respectively :

Options :

41652939026. 25 μ A and 3.5 V

41652939027. 20 μ A and 2.8 V

41652939028. 25 μ A and 2.8 V

41652939029. 20 μ A and 3.5 V

Question Number : 27 Question Id : 4165299892 Question Type : MCQ Option Shuffling : Yes Display Question Number : Yes
Single Line Question Option : No Option Orientation : Vertical

Correct Marks : 4 Wrong Marks : 1

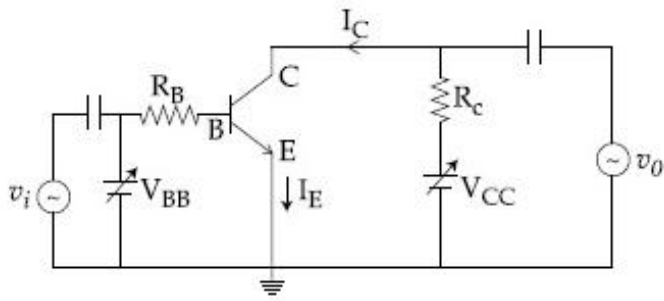

दिखाये गये चित्र में V_{BB} स्रोत 0 से 5.0 V तक बदल सकता है, $V_{CC} = 5$ V, $\beta_{dc} = 200$, $R_B = 100$ k Ω , $R_C = 1$ k Ω और $V_{BE} = 1.0$ V हैं। न्यूनतम आधार धारा तथा निवेशी सिग्नल, जिस पर ट्रांजिस्टर संतृप्ति अवस्था में पहुँच जाये, क्रमशः होंगे :

Options :

41652939026. 25 μ A और 3.5 V
41652939027. 20 μ A और 2.8 V
41652939028. 25 μ A और 2.8 V
41652939029. 20 μ A और 3.5 V

Question Number : 28 Question Id : 4165299893 Question Type : MCQ Option Shuffling : Yes Display Question Number : Yes Single Line Question Option : No Option Orientation : Vertical

Correct Marks : 4 Wrong Marks : 1

To double the covering range of a TV transmission tower, its height should be multiplied by :

Options :

41652939030. 2
41652939031. 4
41652939032. $\sqrt{2}$
41652939033. $\frac{1}{\sqrt{2}}$

Question Number : 28 Question Id : 4165299893 Question Type : MCQ Option Shuffling : Yes Display Question Number : Yes Single Line Question Option : No Option Orientation : Vertical

Correct Marks : 4 Wrong Marks : 1

एक टी.वी. प्रसारण मीनार के विस्तार परास को दोगुना करने के लिए उसकी ऊँचाई को बदलना होगा :

Options :

41652939030. 2 गुना

41652939031. 4 गुना

41652939032. $\sqrt{2}$ गुना

41652939033. $\frac{1}{\sqrt{2}}$ गुना

Question Number : 29 Question Id : 4165299894 Question Type : MCQ Option Shuffling : Yes Display Question Number : Yes
Single Line Question Option : No Option Orientation : Vertical

Correct Marks : 4 Wrong Marks : 1

A load of mass M kg is suspended from a steel wire of length 2 m and radius 1.0 mm in Searle's apparatus experiment. The increase in length produced in the wire is 4.0 mm. Now the load is fully immersed in a liquid of relative density 2. The relative density of the material of load is 8.

The new value of increase in length of the steel wire is :

Options :

41652939034. 4.0 mm

41652939035. 3.0 mm

41652939036. zero

41652939037. 5.0 mm

Question Number : 29 Question Id : 4165299894 Question Type : MCQ Option Shuffling : Yes Display Question Number : Yes
Single Line Question Option : No Option Orientation : Vertical

Correct Marks : 4 Wrong Marks : 1

सर्ल उपकरण के एक प्रयोग में, M kg द्रव्यमान के एक भार को, 2 m लम्बाई तथा 1.0 mm त्रिज्या के एक स्टील के तार से लटकाते हैं। तार की लम्बाई में 4.0 mm की वृद्धि होती है। अब भार को आपेक्षिक घनत्व 2 वाले द्रव में डुबो देते हैं। भार के पदार्थ का आपेक्षिक घनत्व 8 है। तार की लम्बाई में वृद्धि का नया मान होगा :

Options :

41652939034. 4.0 mm

41652939035. 3.0 mm

41652939036. zero

41652939037. 5.0 mm

Question Number : 30 Question Id : 4165299895 Question Type : MCQ Option Shuffling : Yes Display Question Number : Yes
Single Line Question Option : No Option Orientation : Vertical
Correct Marks : 4 Wrong Marks : 1

The charge on a capacitor plate in a circuit, as a function of time, is shown in the figure :

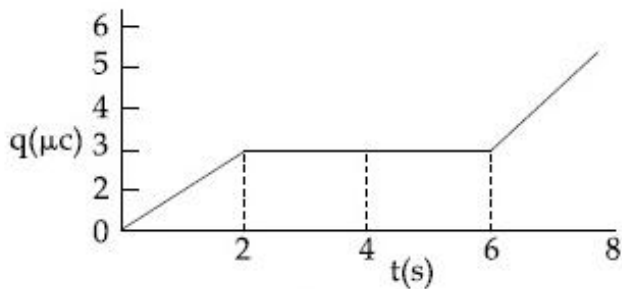

What is the value of current at $t = 4 \text{ s}$?

Options :

41652939038. $3 \mu\text{A}$

41652939039. $1.5 \mu\text{A}$

41652939040. $2 \mu\text{A}$

41652939041. zero

Question Number : 30 Question Id : 4165299895 Question Type : MCQ Option Shuffling : Yes Display Question Number : Yes
Single Line Question Option : No Option Orientation : Vertical
Correct Marks : 4 Wrong Marks : 1

एक परिपथ में संधारित्र की प्लेट पर आवेश का, समय के साथ, फलन चित्र में दिखाया गया है। $t = 4 \text{ s}$ पर धारा का मान क्या है?

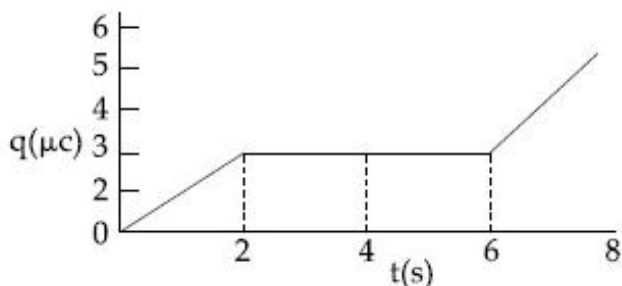

Options :

41652939038. $3 \mu\text{A}$

41652939039. 1.5 μ A

41652939040. 2 μ A

41652939041. zero

	Chemistry
Section Id :	416529152
Section Number :	2
Section type :	Online
Mandatory or Optional:	Mandatory
Number of Questions:	30
Number of Questions to be attempted:	30
Section Marks:	120
Display Number Panel:	Yes
Group All Questions:	No

Sub-Section Number:	1
Sub-Section Id:	416529161
Question Shuffling Allowed :	Yes

Question Number : 31 Question Id : 4165299896 Question Type : MCQ Option Shuffling : Yes Display Question Number : Yes
Single Line Question Option : No Option Orientation : Vertical

Correct Marks : 4 Wrong Marks : 1

The major product of the following reaction is :

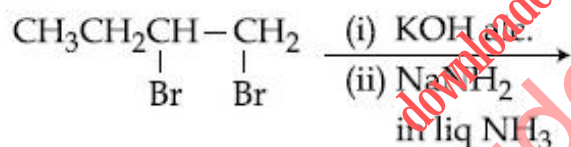

Options :

41652939042. $\text{CH}_3\text{CH}=\text{CHCH}_2\text{NH}_2$

41652939043. $\text{CH}_3\text{CH}=\text{C}=\text{CH}_2$

41652939044. $\text{CH}_3\text{CH}_2\underset{\text{NH}_2}{\text{CH}}-\underset{\text{NH}_2}{\text{CH}_2}$

41652939045. $\text{CH}_3\text{CH}_2\text{C}\equiv\text{CH}$

Question Number : 31 Question Id : 4165299896 Question Type : MCQ Option Shuffling : Yes Display Question Number : Yes
Single Line Question Option : No Option Orientation : Vertical

Correct Marks : 4 Wrong Marks : 1

निम्नलिखित अभिक्रिया का मुख्य उत्पाद है :

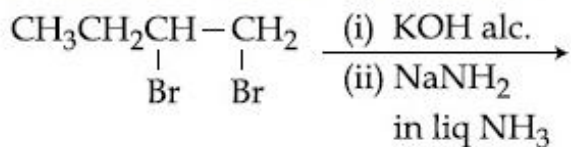

Options :

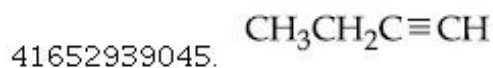
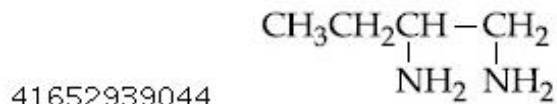
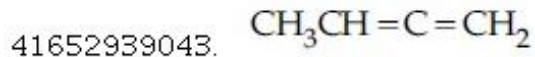

Question Number : 32 Question Id : 4165299897 Question Type : MCQ Option Shuffling : Yes Display Question Number : Yes
Single Line Question Option : No Option Orientation : Vertical

Correct Marks : 4 Wrong Marks : 1

The two monomers for the synthesis of Nylon 6, 6 are :

Options :

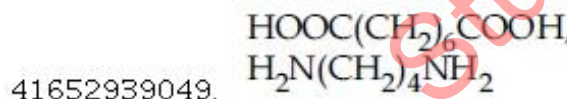
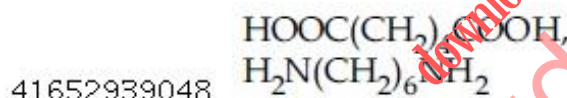
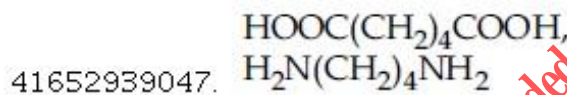
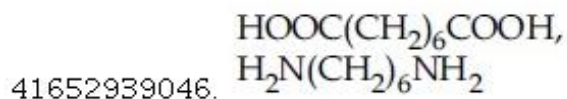

Question Number : 32 Question Id : 4165299897 Question Type : MCQ Option Shuffling : Yes Display Question Number : Yes
Single Line Question Option : No Option Orientation : Vertical

Correct Marks : 4 Wrong Marks : 1

नाइलॉन 6, 6 के संश्लेषण के लिए दो एकलक हैं :

Options :

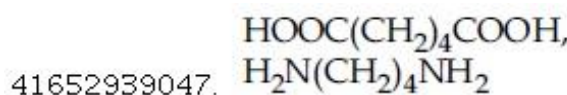
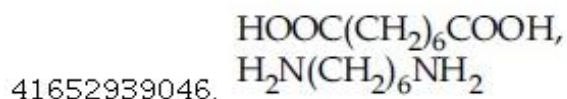

41652939048.

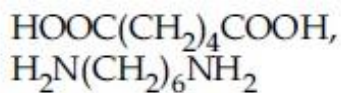

41652939049.

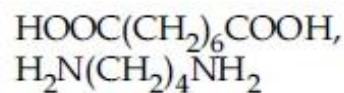

Question Number : 33 Question Id : 4165299898 Question Type : MCQ Option Shuffling : Yes Display Question Number : Yes
Single Line Question Option : No Option Orientation : Vertical

Correct Marks : 4 Wrong Marks : 1

The major product of the following reaction is :

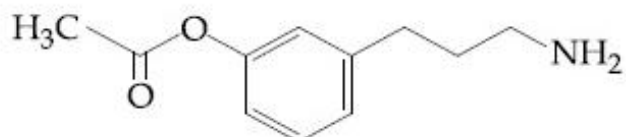

(i) NaNO_2/H^+

(ii) CrO_3/H^+

(iii) H_2SO_4 (conc.), Δ

Options :

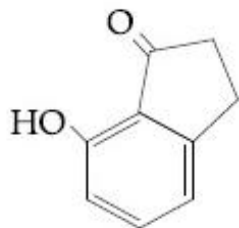

41652939050.

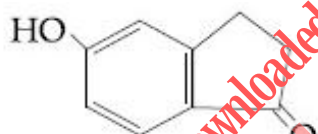

41652939051.

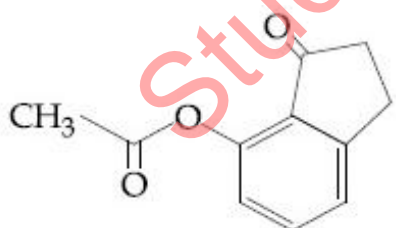

41652939052.

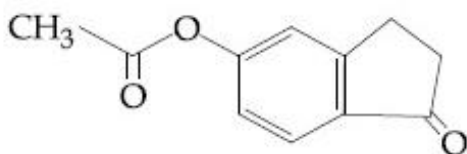

41652939053.

Question Number : 33 Question Id : 4165299898 Question Type : MCQ Option Shuffling : Yes Display Question Number : Yes
Single Line Question Option : No Option Orientation : Vertical

Correct Marks : 4 Wrong Marks : 1

निम्नलिखित अभिक्रिया का मुख्य उत्पाद है :

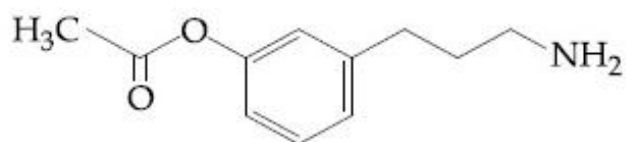

(i) NaNO_2/H^+

(ii) CrO_3/H^+

(iii) H_2SO_4 (conc.), Δ

Options :

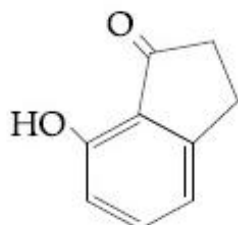

41652939050.

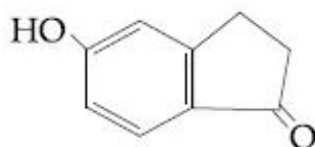

41652939051.

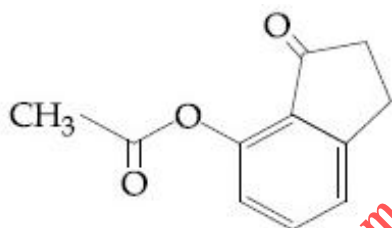

41652939052.

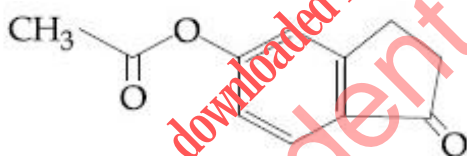

41652939053.

Question Number : 34 Question Id : 4165299899 Question Type : MCQ Option Shuffling : Yes Display Question Number : Yes
Single Line Question Option : No Option Orientation : Vertical

Correct Marks : 4 Wrong Marks : 1

The correct structure of histidine in a strongly acidic solution ($\text{pH} = 2$) is :

Options :

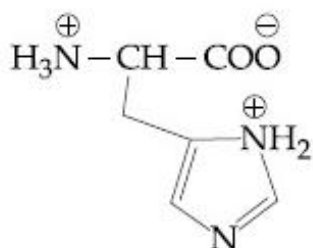

41652939054.

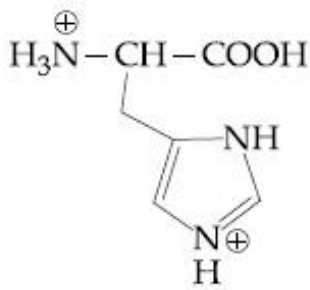

41652939055.

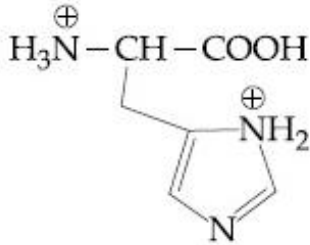

41652939056.

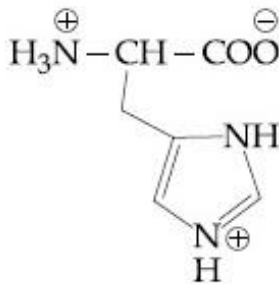

41652939057.

Question Number : 34 Question Id : 4165299899 Question Type : MCQ Option Shuffling : Yes Display Question Number : Yes
Single Line Question Option : No Option Orientation : Vertical

Correct Marks : 4 Wrong Marks : 1

एक सान्द्र अम्लीय विलयन (pH = 2) में, हिस्टीडीन की सही संरचना है :

Options :

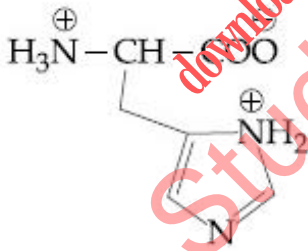

41652939054.

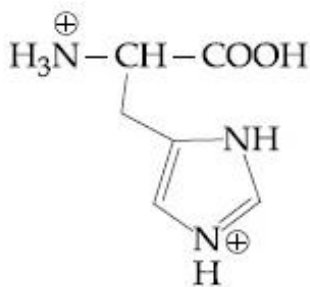

41652939055.

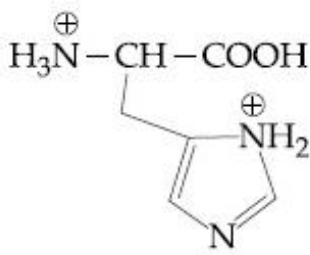

41652939056.

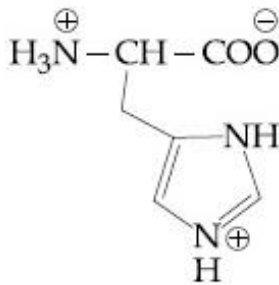

41652939057.

Question Number : 35 Question Id : 4165299900 Question Type : MCQ Option Shuffling : Yes Display Question Number : Yes
Single Line Question Option : No Option Orientation : Vertical

Correct Marks : 4 Wrong Marks : 1

The major product of the following reaction
is :

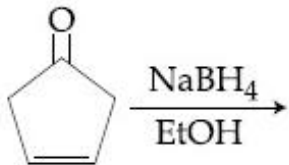

Options :

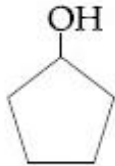

41652939058.



41652939059.



41652939060.

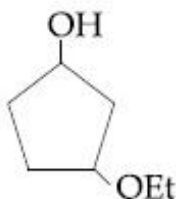

41652939061.

Question Number : 35 Question Id : 4165299900 Question Type : MCQ Option Shuffling : Yes Display Question Number : Yes
Single Line Question Option : No Option Orientation : Vertical

Correct Marks : 4 Wrong Marks : 1

निम्नलिखित अभिक्रिया का मुख्य उत्पाद है :

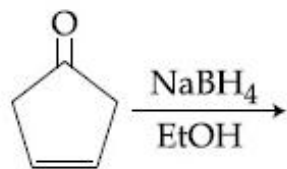

Options :

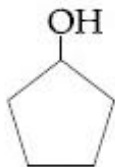

41652939058.

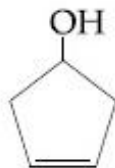

41652939059.



41652939060.

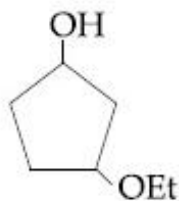

41652939061.

Question Number : 36 Question Id : 4165299901 Question Type : MCQ Option Shuffling : Yes Display Question Number : Yes
Single Line Question Option : No Option Orientation : Vertical

Correct Marks : 4 Wrong Marks : 1

The aldehydes which will not form Grignard product with one equivalent Grignard reagents are :

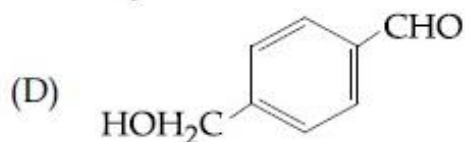
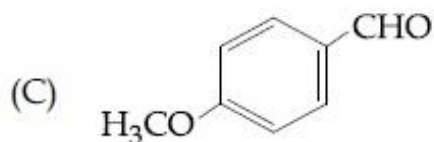
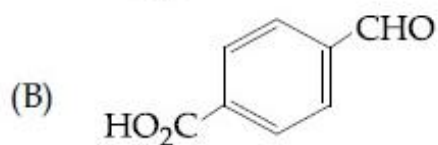

Options :

41652939062. (B), (C)

41652939063. (B), (D)

41652939064. (B), (C), (D)

41652939065. (C), (D)

Question Number : 36 Question Id : 4165299901 Question Type : MCQ Option Shuffling : Yes Display Question Number : Yes
Single Line Question Option : No Option Orientation : Vertical

Correct Marks : 4 Wrong Marks : 1

एक समतुल्य ग्रिन्यार अभिक्रिया के साथ ग्रिन्यार उत्पाद नहीं देने वाले ऐलिडहाइड हैं :

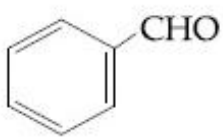
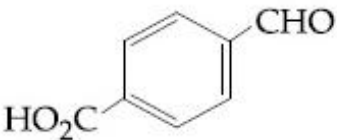
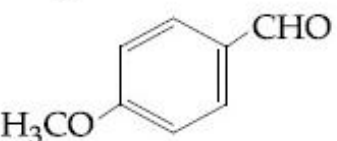
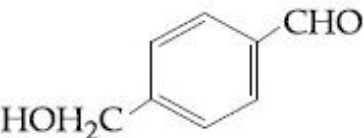
- (A) 
- (B) 
- (C) 
- (D) 

Options :

41652939062. (B), (C)

41652939063. (B), (D)

41652939064. (B), (C), (D)

41652939065. (C), (D)

Question Number : 37 Question Id : 4165299902 Question Type : MCQ Option Shuffling : Yes Display Question Number : Yes
Single Line Question Option : No Option Orientation : Vertical

Correct Marks : 4 Wrong Marks : 1

The increasing order of the reactivity of the following with LiAlH_4 is :

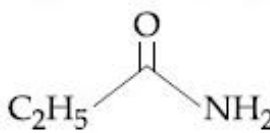
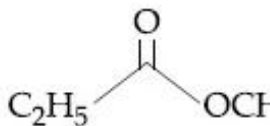
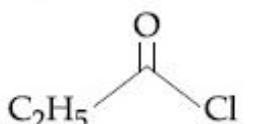
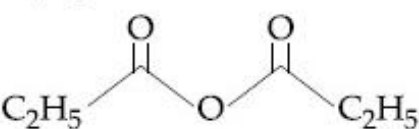
- (A) 
- (B) 
- (C) 
- (D) 

Options :

41652939066. (A) < (B) < (C) < (D)

41652939067. (B) < (A) < (D) < (C)

41652939068. (A) < (B) < (D) < (C)

41652939069. (B) < (A) < (C) < (D)

Question Number : 37 Question Id : 4165299902 Question Type : MCQ Option Shuffling : Yes Display Question Number : Yes
Single Line Question Option : No Option Orientation : Vertical

Correct Marks : 4 Wrong Marks : 1

निम्नलिखित की LiAlH_4 के साथ अभिक्रियाशीलता का बढ़ता क्रम है :

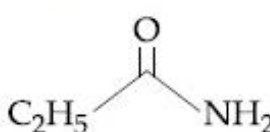
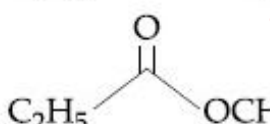
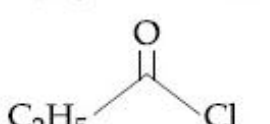
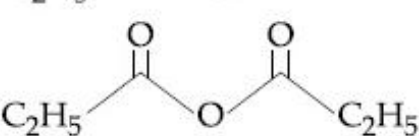
- (A) 
- (B) 
- (C) 
- (D) 

Options :

41652939066. (A) < (B) < (C) < (D)

41652939067. (B) < (A) < (D) < (C)

41652939068. (A) < (B) < (D) < (C)

41652939069. (B) < (A) < (C) < (D)

Question Number : 38 Question Id : 4165299903 Question Type : MCQ Option Shuffling : Yes Display Question Number : Yes
Single Line Question Option : No Option Orientation : Vertical

Correct Marks : 4 Wrong Marks : 1

The major product of the following reaction is :

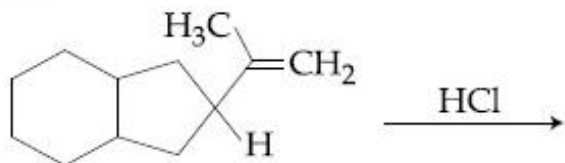

Options :

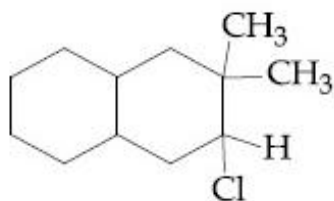

41652939070.

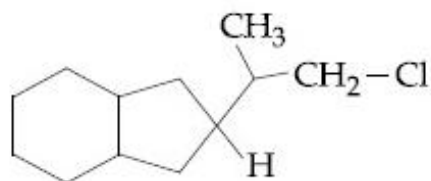

41652939071.

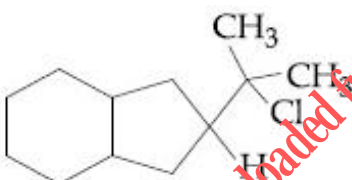

41652939072.

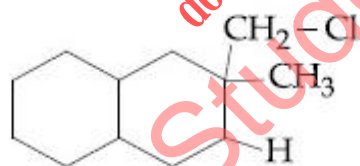

41652939073.

Question Number : 38 Question Id : 4165299903 Question Type : MCQ Option Shuffling : Yes Display Question Number : Yes
Single Line Question Option : No Option Orientation : Vertical

Correct Marks : 4 Wrong Marks : 1

निम्नलिखित अभिक्रिया का मुख्य उत्पाद है :

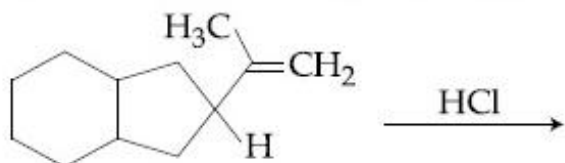

Options :

41652939070.

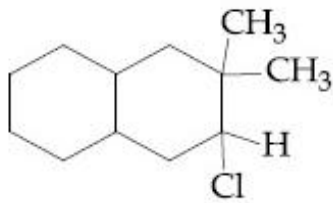

41652939071.

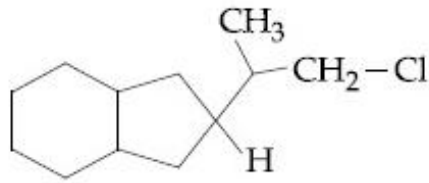

41652939072.

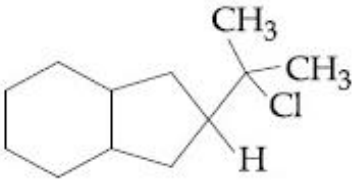

41652939073.

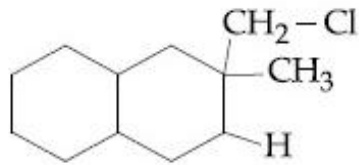

Question Number : 39 Question Id : 4165299904 Question Type : MCQ Option Shuffling : Yes Display Question Number : Yes
Single Line Question Option : No Option Orientation : Vertical

Correct Marks : 4 Wrong Marks : 1

The major product in the following conversion is :

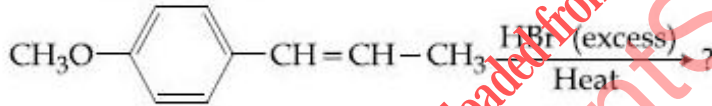

Options :

41652939074.

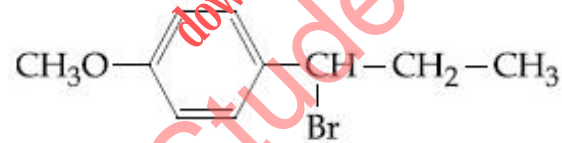

41652939075.

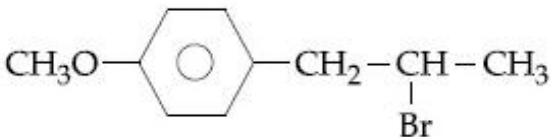

41652939076.

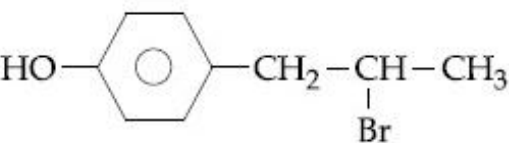

41652939077.

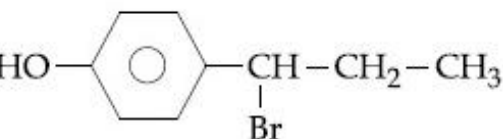

Question Number : 39 Question Id : 4165299904 Question Type : MCQ Option Shuffling : Yes Display Question Number : Yes
Single Line Question Option : No Option Orientation : Vertical

Correct Marks : 4 Wrong Marks : 1

निम्नलिखित रूपान्तरण में सही उत्पाद है :

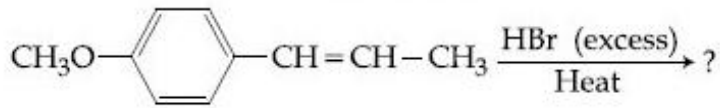

Options :

41652939074.

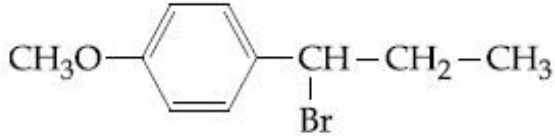

41652939075.

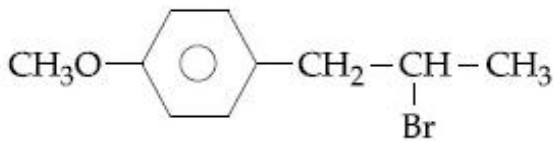

41652939076.

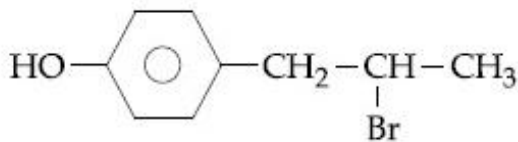

41652939077.

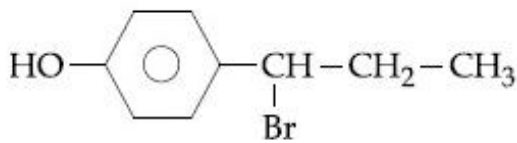

Question Number : 40 Question Id : 4165299905 Question Type : MCQ Option Shuffling : Yes Display Question Number : Yes
Single Line Question Option : No Option Orientation : Vertical

Correct Marks : 4 Wrong Marks : 1

The major product of the following reaction is :

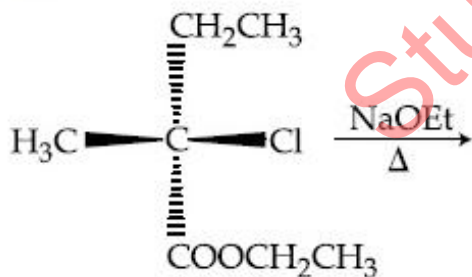

Options :

41652939078.

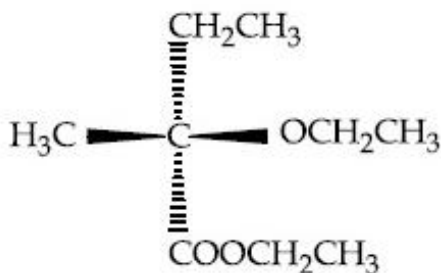

41652939079.

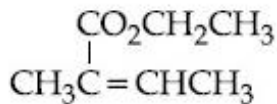

41652939080.

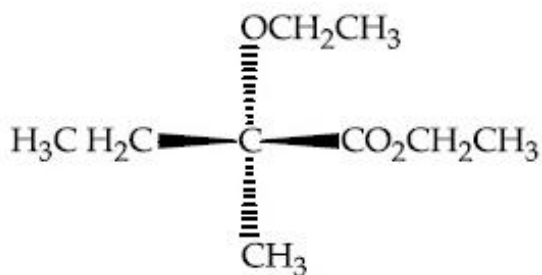

41652939081.

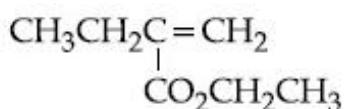

Question Number : 40 Question Id : 4165299905 Question Type : MCQ Option Shuffling : Yes Display Question Number : Yes
Single Line Question Option : No Option Orientation : Vertical

Correct Marks : 4 Wrong Marks : 1

निम्नलिखित अभिक्रिया का मुख्य उत्पाद है :

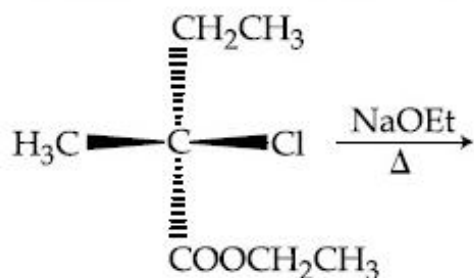

Options :

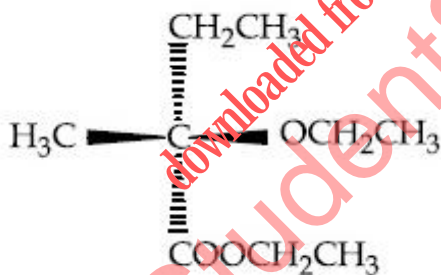

41652939078.

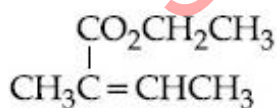

41652939079.

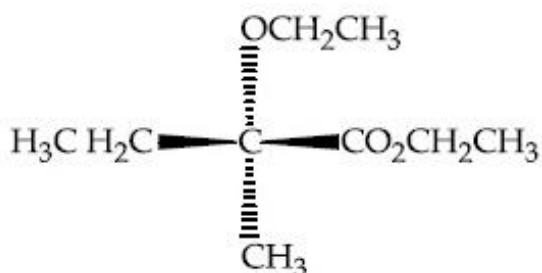

41652939080.

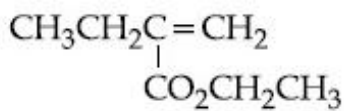

41652939081.

Question Number : 41 Question Id : 4165299906 Question Type : MCQ Option Shuffling : Yes Display Question Number : Yes
Single Line Question Option : No Option Orientation : Vertical

Correct Marks : 4 Wrong Marks : 1

The element that shows greater ability to form $p\pi - p\pi$ multiple bonds, is :

Options :

41652939082. Si

41652939083. C

41652939084. Ge

41652939085. Sn

Question Number : 41 Question Id : 4165299906 Question Type : MCQ Option Shuffling : Yes Display Question Number : Yes
Single Line Question Option : No Option Orientation : Vertical

Correct Marks : 4 Wrong Marks : 1

$p\pi - p\pi$ बहुबंध बनाने की प्रबल योग्यता रखने वाला तत्व है :

Options :

41652939082. Si

41652939083. C

41652939084. Ge

41652939085. Sn

Question Number : 42 Question Id : 4165299907 Question Type : MCQ Option Shuffling : Yes Display Question Number : Yes
Single Line Question Option : No Option Orientation : Vertical

Correct Marks : 4 Wrong Marks : 1

The pair that does NOT require calcination is :

Options :

41652939086. ZnO and $\text{Fe}_2\text{O}_3 \cdot x\text{H}_2\text{O}$

41652939087. ZnCO_3 and CaO

41652939088. ZnO and MgO

41652939089. Fe_2O_3 and $\text{CaCO}_3 \cdot \text{MgCO}_3$

Question Number : 42 Question Id : 4165299907 Question Type : MCQ Option Shuffling : Yes Display Question Number : Yes
Single Line Question Option : No Option Orientation : Vertical

Correct Marks : 4 Wrong Marks : 1

युग्म जिसके लिए निस्तापन की आवश्यकता नहीं होती है, वह है :

Options :

41652939086. ZnO तथा $\text{Fe}_2\text{O}_3 \cdot x\text{H}_2\text{O}$

41652939087. ZnCO_3 तथा CaO

41652939088. ZnO तथा MgO

41652939089. Fe_2O_3 तथा $\text{CaCO}_3 \cdot \text{MgCO}_3$

Question Number : 43 Question Id : 4165299908 Question Type : MCQ Option Shuffling : Yes Display Question Number : Yes
Single Line Question Option : No Option Orientation : Vertical

Correct Marks : 4 Wrong Marks : 1

The volume strength of 1M H_2O_2 is :
(Molar mass of $\text{H}_2\text{O}_2 = 34 \text{ g mol}^{-1}$)

Options :

41652939090. 5.6

41652939091. 11.35

41652939092. 16.8

41652939093. 22.4

Question Number : 43 Question Id : 4165299908 Question Type : MCQ Option Shuffling : Yes Display Question Number : Yes
Single Line Question Option : No Option Orientation : Vertical

Correct Marks : 4 Wrong Marks : 1

1M H_2O_2 का आयतन सामर्थ्य है (H_2O_2 का मोलर द्रव्यमान = 34 ग्रा. मोल⁻¹)

Options :

41652939090. 5.6

41652939091. 11.35

41652939092. 16.8

Question Number : 44 Question Id : 4165299909 Question Type : MCQ Option Shuffling : Yes Display Question Number : Yes
Single Line Question Option : No Option Orientation : Vertical

Correct Marks : 4 Wrong Marks : 1

The correct statement(s) among I to III with respect to potassium ions that are abundant within the cell fluids is/are :

- I. They activate many enzymes
- II. They participate in the oxidation of glucose to produce ATP
- III. Along with sodium ions, they are responsible for the transmission of nerve signals

Options :

41652939094. I, II and III

41652939095. I and II only

41652939096. III only

41652939097. I and III only

Question Number : 44 Question Id : 4165299909 Question Type : MCQ Option Shuffling : Yes Display Question Number : Yes
Single Line Question Option : No Option Orientation : Vertical

Correct Marks : 4 Wrong Marks : 1

कोशिका तरल में बाहुल्य रूप में पाये जाने वाले सोडियम आयनों के संबंध में I से III में से सही कथन है/हैं?

- I. वे कई एंजाइमों को सक्रिय करते हैं।
- II. वे ग्लूकोस के आक्सीकरण द्वारा ATP के बनाने में भागीदारी करते हैं।
- III. सोडियम आयन के साथ, तंत्रिकाओं के संकेतों के संचरण के लिए जिम्मेदार होते हैं।

Options :

41652939094. I, II तथा III

41652939095. केवल I तथा II

41652939096. केवल III

41652939097. केवल I तथा III

Question Number : 45 Question Id : 4165299910 Question Type : MCQ Option Shuffling : Yes Display Question Number : Yes
Single Line Question Option : No Option Orientation : Vertical

Correct Marks : 4 Wrong Marks : 1

The element that does NOT show catenation is :

Options :

41652939098. Si

41652939099. Ge

41652939100. Sn

41652939101. Pb

Question Number : 45 Question Id : 4165299910 Question Type : MCQ Option Shuffling : Yes Display Question Number : Yes
Single Line Question Option : No Option Orientation : Vertical

Correct Marks : 4 Wrong Marks : 1

शृंखलन नहीं प्रदर्शित करने वाला तत्व है :

Options :

41652939098. Si

41652939099. Ge

41652939100. Sn

41652939101. Pb

Question Number : 46 Question Id : 4165299911 Question Type : MCQ Option Shuffling : Yes Display Question Number : Yes
Single Line Question Option : No Option Orientation : Vertical

Correct Marks : 4 Wrong Marks : 1

Chlorine on reaction with hot and concentrated sodium hydroxide gives :

Options :

41652939102. ClO_3^- and ClO_2^-

41652939103. Cl^- and ClO_3^-

41652939104. Cl^- and ClO_2^-

41652939105. Cl^- and ClO^-

Question Number : 46 Question Id : 4165299911 Question Type : MCQ Option Shuffling : Yes Display Question Number : Yes
Single Line Question Option : No Option Orientation : Vertical

Correct Marks : 4 Wrong Marks : 1

गर्म तथा सान्द्र सोडियम हाइड्राक्साइड के साथ क्लोरीन की अभिक्रिया देती है :

Options :

41652939102. ClO_3^- तथा ClO_2^-

41652939103. Cl^- तथा ClO_3^-

41652939104. Cl^- तथा ClO_2^-

41652939105. Cl^- तथा ClO^-

Question Number : 47 Question Id : 4165299912 Question Type : MCQ Option Shuffling : Yes Display Question Number : Yes
Single Line Question Option : No Option Orientation : Vertical

Correct Marks : 4 Wrong Marks : 1

The correct order of atomic radii is :

Options :

41652939106. $\text{Eu} > \text{Ce} > \text{Ho} > \text{N}$

41652939107. $\text{Ce} > \text{Eu} > \text{Ho} > \text{N}$

41652939108. $\text{N} > \text{Ce} > \text{Eu} > \text{Ho}$

41652939109. $\text{Ho} > \text{N} > \text{Eu} > \text{Ce}$

Question Number : 47 Question Id : 4165299912 Question Type : MCQ Option Shuffling : Yes Display Question Number : Yes
Single Line Question Option : No Option Orientation : Vertical

Correct Marks : 4 Wrong Marks : 1

परमाणु त्रिज्याओं का सही क्रम है :

Options :

41652939106. $\text{Eu} > \text{Ce} > \text{Ho} > \text{N}$

41652939107. $\text{Ce} > \text{Eu} > \text{Ho} > \text{N}$

41652939108. $\text{N} > \text{Ce} > \text{Eu} > \text{Ho}$

41652939109. $\text{Ho} > \text{N} > \text{Eu} > \text{Ce}$

Question Number : 48 Question Id : 4165299913 Question Type : MCQ Option Shuffling : Yes Display Question Number : Yes
Single Line Question Option : No Option Orientation : Vertical

Correct Marks : 4 Wrong Marks : 1

The magnetic moment of an octahedral homoleptic Mn(II) complex is 5.9 BM. The suitable ligand for this complex is :

Options :

41652939110. CO
41652939111. NCS⁻
41652939112. CN⁻
41652939113. ethylenediamine

Question Number : 48 Question Id : 4165299913 Question Type : MCQ Option Shuffling : Yes Display Question Number : Yes
Single Line Question Option : No Option Orientation : Vertical

Correct Marks : 4 Wrong Marks : 1

एक अष्टफलक होमोलेप्टिक Mn(II) के संकुल का चुंबकीय आघूर्ण 5.9 BM है। इस संकुल के लिए उपयुक्त संलग्नी है :

Options :

41652939110. CO
41652939111. NCS⁻
41652939112. CN⁻
41652939113. ethylenediamine

Question Number : 49 Question Id : 4165299914 Question Type : MCQ Option Shuffling : Yes Display Question Number : Yes
Single Line Question Option : No Option Orientation : Vertical

Correct Marks : 4 Wrong Marks : 1

The upper stratosphere consisting of the ozone layer protects us from the sun's radiation that falls in the wavelength region of :

Options :

41652939114. 0.8 - 1.5 nm
41652939115. 200 - 315 nm
41652939116. 400 - 550 nm
41652939117. 600 - 750 nm

Question Number : 49 Question Id : 4165299914 Question Type : MCQ Option Shuffling : Yes Display Question Number : Yes
Single Line Question Option : No Option Orientation : Vertical

Correct Marks : 4 Wrong Marks : 1

ऊपरी समतापमंडल जिसमें उपस्थित ओजोन परत हमें
सूर्य के विकिरण से बचाती है, उसका तरंगदैर्घ्य क्षेत्र
है :

Options :

41652939114. 0.8 - 1.5 nm

41652939115. 200 - 315 nm

41652939116. 400 - 550 nm

41652939117. 600 - 750 nm

Question Number : 50 Question Id : 4165299915 Question Type : MCQ Option Shuffling : Yes Display Question Number : Yes
Single Line Question Option : No Option Orientation : Vertical

Correct Marks : 4 Wrong Marks : 1

The compound that is NOT a common
component of photochemical smog is :

Options :

41652939118. O_3

41652939119. $CH_2=CHCHO$

41652939120. CF_2Cl_2

41652939121. $H_3C-C(=O)NO_2$

Question Number : 50 Question Id : 4165299915 Question Type : MCQ Option Shuffling : Yes Display Question Number : Yes
Single Line Question Option : No Option Orientation : Vertical

Correct Marks : 4 Wrong Marks : 1

प्रकाश रासायनिक धूमकुहा का जो सामान्य संघटक
नहीं है, वह यौगिक है :

Options :

41652939118. O_3

41652939119. $CH_2=CHCHO$

41652939120. CF_2Cl_2

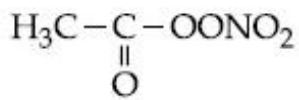

41652939121.

Question Number : 51 Question Id : 4165299916 Question Type : MCQ Option Shuffling : Yes Display Question Number : Yes
Single Line Question Option : No Option Orientation : Vertical

Correct Marks : 4 Wrong Marks : 1

8 g of NaOH is dissolved in 18 g of H₂O.
Mole fraction of NaOH in solution and
molality (in mol kg⁻¹) of the solution
respectively are :

Options :

41652939122. 0.167, 11.11

41652939123. 0.2, 11.11

41652939124. 0.167, 22.20

41652939125. 0.2, 22.20

Question Number : 51 Question Id : 4165299916 Question Type : MCQ Option Shuffling : Yes Display Question Number : Yes
Single Line Question Option : No Option Orientation : Vertical

Correct Marks : 4 Wrong Marks : 1

8 g NaOH को 18 g H₂O में घोला गया है। विलयन
में NaOH का मोलांश तथा विलयन की मोलालिटी
(मोल प्रति किलोग्राम) क्रमशः है :

Options :

41652939122. 0.167, 11.11

41652939123. 0.2, 11.11

41652939124. 0.167, 22.20

41652939125. 0.2, 22.20

Question Number : 52 Question Id : 4165299917 Question Type : MCQ Option Shuffling : Yes Display Question Number : Yes
Single Line Question Option : No Option Orientation : Vertical

Correct Marks : 4 Wrong Marks : 1

An open vessel at 27°C is heated until two
fifth of the air (assumed as an ideal gas) in
it has escaped from the vessel. Assuming
that the volume of the vessel remains
constant, the temperature at which the
vessel has been heated is :

Options :

41652939126. 500 °C

41652939127. 500 K

41652939128. 750 K

41652939129. 750 °C

Question Number : 52 Question Id : 4165299917 Question Type : MCQ Option Shuffling : Yes Display Question Number : Yes
Single Line Question Option : No Option Orientation : Vertical

Correct Marks : 4 Wrong Marks : 1

27°C पर स्थित एक खुले पात्र को तब तक गर्म किया जाता है जब तक इसमें उपस्थित वायु (आदर्श गैस मानते हुए) के दो के पाँचवें भाग (2/5) पात्र से निकल नहीं जाता। यह मानकर कि पात्र का आयतन स्थिर है, ताप जिस पर पात्र को गर्म किया गया है, वह है :

Options :

41652939126. 500 °C

41652939127. 500 K

41652939128. 750 K

41652939129. 750 °C

Question Number : 53 Question Id : 4165299918 Question Type : MCQ Option Shuffling : Yes Display Question Number : Yes
Single Line Question Option : No Option Orientation : Vertical

Correct Marks : 4 Wrong Marks : 1

If the de Broglie wavelength of the electron in n^{th} Bohr orbit in a hydrogenic atom is equal to $1.5 \pi a_0$ (a_0 is Bohr radius), then the value of n/z is :

Options :

41652939130. 1.0

41652939131. 1.50

41652939132. 0.75

41652939133. 0.40

Question Number : 53 Question Id : 4165299918 Question Type : MCQ Option Shuffling : Yes Display Question Number : Yes
Single Line Question Option : No Option Orientation : Vertical

Correct Marks : 4 Wrong Marks : 1

यदि एक हाइड्रोजन परमाणु में, n वें (n^{th}) बोर कक्षक में स्थित इलेक्ट्रॉन का दे ब्राग्ली तरंगदैर्घ्य $1.5 \pi a_0$ के बराबर है, तो n/z का मान है : (a_0 बोर त्रिज्या है)

Options :

41652939130. 1.0

41652939131. 1.50

41652939132. 0.75

41652939133. 0.40

Question Number : 54 Question Id : 4165299919 Question Type : MCQ Option Shuffling : Yes Display Question Number : Yes Single Line Question Option : No Option Orientation : Vertical

Correct Marks : 4 Wrong Marks : 1

The combination of plots which does not represent isothermal expansion of an ideal gas is :

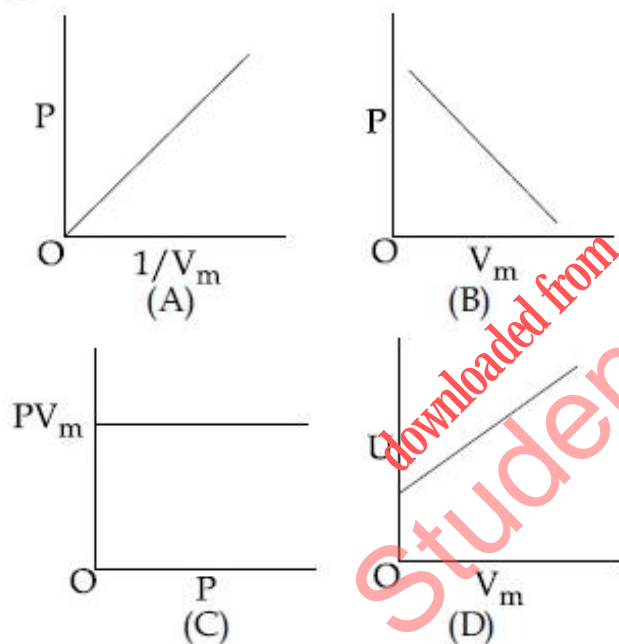

Options :

41652939134. (B) and (C)

41652939135. (A) and (D)

41652939136. (B) and (D)

41652939137. (A) and (C)

Question Number : 54 Question Id : 4165299919 Question Type : MCQ Option Shuffling : Yes Display Question Number : Yes Single Line Question Option : No Option Orientation : Vertical

Correct Marks : 4 Wrong Marks : 1

एक आदर्श गैस के समतापीय प्रसरण को नहीं निरूपित करने वाले प्लोटों का संयोजन है :

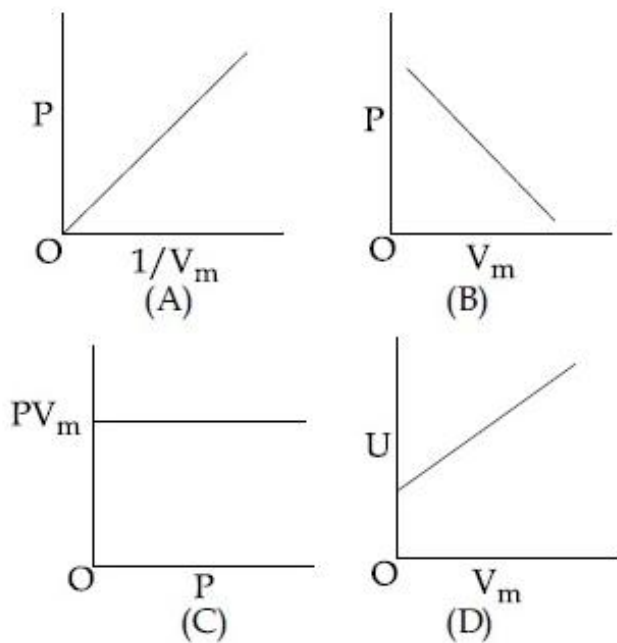

Options :

41652939134. (B) तथा (C)

41652939135. (A) तथा (D)

41652939136. (B) तथा (D)

41652939137. (A) तथा (C)

Question Number : 55 Question Id : 4165293920 Question Type : MCQ Option Shuffling : Yes Display Question Number : Yes Single Line Question Option : No Option Orientation : Vertical

Correct Marks : 4 Wrong Marks : 1

Given :

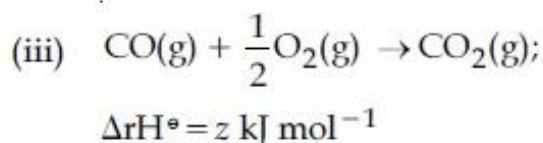
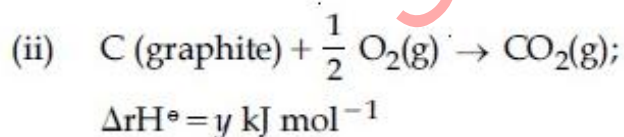
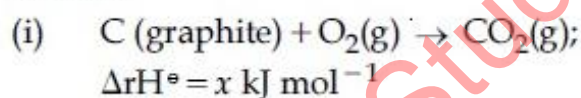

Based on the above thermochemical equations, find out which one of the following algebraic relationships is correct?

Options :

41652939138. $x = y + z$

41652939139. $x = y - z$

41652939140. $z = x + y$

41652939141. $y = 2z - x$

Question Number : 55 Question Id : 4165299920 Question Type : MCQ Option Shuffling : Yes Display Question Number : Yes
Single Line Question Option : No Option Orientation : Vertical

Correct Marks : 4 Wrong Marks : 1

दिया गया है :

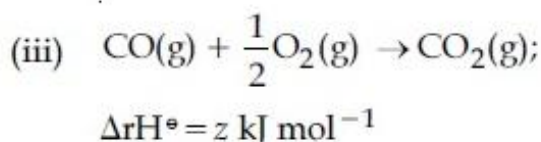
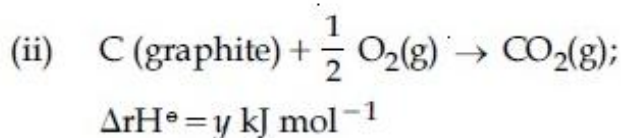
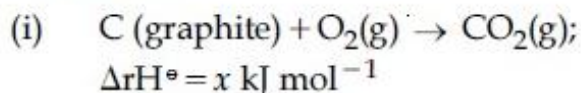

उपर्युक्त ऊष्मारासायनिक समीकरणों के आधार पर बताइये कि नीचे दिए गये बीजगणितीय संबंधों में से कौन सा सही है?

Options :

41652939138. $x = y + z$

41652939139. $x = y - z$

41652939140. $z = x + y$

41652939141. $y = 2z - x$

Question Number : 56 Question Id : 4165299921 Question Type : MCQ Option Shuffling : Yes Display Question Number : Yes
Single Line Question Option : No Option Orientation : Vertical

Correct Marks : 4 Wrong Marks : 1

Molecules of benzoic acid (C_6H_5COOH) dimerise in benzene. 'w' g of the acid dissolved in 30 g of benzene shows a depression in freezing point equal to 2 K. If the percentage association of the acid to form dimer in the solution is 80, then w is :
(Given that $K_f = 5 \text{ K kg mol}^{-1}$, Molar mass of benzoic acid = 122 g mol^{-1})

Options :

41652939142. 1.0 g

41652939143. 1.8 g

41652939144. 2.4 g

41652939145. 1.5 g

Question Number : 56 Question Id : 4165299921 Question Type : MCQ Option Shuffling : Yes Display Question Number : Yes
Single Line Question Option : No Option Orientation : Vertical

Correct Marks : 4 Wrong Marks : 1

बेन्जोइक अम्ल (C_6H_5COOH) के अणु बेन्जीन में द्वितयित होते हैं। 30 g बेन्जीन में घुलित 'w' g अम्ल 2 K के बराबर हिमांक में अवनमन प्रदर्शित करता है। यदि विलयन में अम्ल के संगुणन का प्रतिशत 80 है तो w का मान है :

(दिया गया है, $K_f = 5 K kg mol^{-1}$ बेन्जोइक एसिड का मोलर द्रव्यमान = $122 g mol^{-1}$)

Options :

41652939142. 1.0 g

41652939143. 1.8 g

41652939144. 2.4 g

41652939145. 1.5 g

Question Number : 57 Question Id : 4165299922 Question Type : MCQ Option Shuffling : Yes Display Question Number : Yes
Single Line Question Option : No Option Orientation : Vertical

Correct Marks : 4 Wrong Marks : 1

If K_{sp} of Ag_2CO_3 is 8×10^{-12} , the molar solubility of Ag_2CO_3 in 0.1 M $AgNO_3$ is :

Options :

41652939146. $8 \times 10^{-10} M$

41652939147. $8 \times 10^{-11} M$

41652939148. $8 \times 10^{-12} M$

41652939149. $8 \times 10^{-13} M$

Question Number : 57 Question Id : 4165299922 Question Type : MCQ Option Shuffling : Yes Display Question Number : Yes
Single Line Question Option : No Option Orientation : Vertical

Correct Marks : 4 Wrong Marks : 1

यदि Ag_2CO_3 का K_{sp} 8×10^{-12} है तो Ag_2CO_3 की 0.1 M AgNO_3 में मोलर विलेयता है :

Options :

41652939146. 8×10^{-10} M

41652939147. 8×10^{-11} M

41652939148. 8×10^{-12} M

41652939149. 8×10^{-13} M

Question Number : 58 Question Id : 4165299923 Question Type : MCQ Option Shuffling : Yes Display Question Number : Yes Single Line Question Option : No Option Orientation : Vertical

Correct Marks : 4 Wrong Marks : 1

\wedge_m° for NaCl, HCl and NaA are 126.4, 425.9 and $100.5 \text{ S cm}^2\text{mol}^{-1}$, respectively. If the conductivity of 0.001 M HA is $5 \times 10^{-5} \text{ S cm}^{-1}$, degree of dissociation of HA is :

Options :

41652939150. 0.25

41652939151. 0.125

41652939152. 0.50

41652939153. 0.75

Question Number : 58 Question Id : 4165299923 Question Type : MCQ Option Shuffling : Yes Display Question Number : Yes Single Line Question Option : No Option Orientation : Vertical

Correct Marks : 4 Wrong Marks : 1

NaCl, HCl तथा NaA के लिए \wedge_m° क्रमशः 126.4, 425.9 तथा $100.5 \text{ S cm}^2\text{mol}^{-1}$ हैं। यदि 0.001 M HA की चालकता $5 \times 10^{-5} \text{ S cm}^{-1}$ हो तो HA की वियोजन मात्रा है :

Options :

41652939150. 0.25

41652939151. 0.125

41652939152. 0.50

Question Number : 59 Question Id : 416529924 Question Type : MCQ Option Shuffling : Yes Display Question Number : Yes
Single Line Question Option : No Option Orientation : Vertical

Correct Marks : 4 Wrong Marks : 1

For a reaction, consider the plot of $\ln k$ versus $1/T$ given in the figure. If the rate constant of this reaction at 400 K is 10^{-5} s^{-1} , then the rate constant at 500 K is :

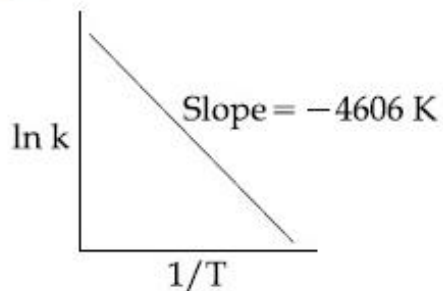

Options :

41652939154. 10^{-4} s^{-1}

41652939155. 10^{-6} s^{-1}

41652939156. $2 \times 10^{-4} \text{ s}^{-1}$

41652939157. $4 \times 10^{-4} \text{ s}^{-1}$

Question Number : 59 Question Id : 416529924 Question Type : MCQ Option Shuffling : Yes Display Question Number : Yes
Single Line Question Option : No Option Orientation : Vertical

Correct Marks : 4 Wrong Marks : 1

एक अभिक्रिया के लिए दिये गये चित्र में $\ln k$ vs $1/T$ के प्लॉट पर विचार कीजिए। यदि इस अभिक्रिया का दर नियतांक 400 K पर 10^{-5} s^{-1} है, तो 500 K पर उसका दर नियतांक है :

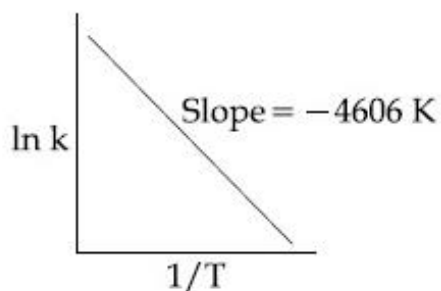

Options :

41652939154. 10^{-4} s^{-1}

41652939155. 10^{-6} s^{-1}

41652939156. $2 \times 10^{-4} \text{ s}^{-1}$

41652939157. $4 \times 10^{-4} \text{ s}^{-1}$

Question Number : 60 Question Id : 4165299925 Question Type : MCQ Option Shuffling : Yes Display Question Number : Yes
Single Line Question Option : No Option Orientation : Vertical

Correct Marks : 4 Wrong Marks : 1

Among the following, the false statement is :

Options :

41652939158. Tyndall effect can be used to distinguish between a colloidal solution and a true solution.

41652939159. Latex is a colloidal solution of rubber particles which are positively charged

41652939160. It is possible to cause artificial rain by throwing electrified sand carrying charge opposite to the one on clouds from an aeroplane.

41652939161. Lyophilic sol can be coagulated by adding an electrolyte.

Question Number : 60 Question Id : 4165299925 Question Type : MCQ Option Shuffling : Yes Display Question Number : Yes
Single Line Question Option : No Option Orientation : Vertical

Correct Marks : 4 Wrong Marks : 1

निम्नलिखित में से, असत्य कथन है :

Options :

41652939158. टिन्डल प्रभाव का उपयोग एक कोलॉइडी विलयन तथा वास्तविक विलयन में अंतर करने के लिए किया जा सकता है।

41652939159. लेटेक्स, रबर के कणों का एक कोलॉइडी विलयन है, जो धनावेशित होते हैं।

41652939160. वायुयान की सहायता से बादलों पर उपस्थित आवेश से विपरीत आवेशित रेत के कणों को फेंक कर कृत्रिम वर्षा करवाना संभव है।

द्रवरागी सॉल का स्कन्दन एक विद्युत अपघट्य
मिलाकर किया जा सकता है।

41652939161.

Section Id :	Mathematics
Section Number :	416529153
Section type :	3
Mandatory or Optional:	Online
Number of Questions:	Mandatory
Number of Questions to be attempted:	30
Section Marks:	30
Display Number Panel:	120
Group All Questions:	Yes
	No

Sub-Section Number:	1
Sub-Section Id:	416529162
Question Shuffling Allowed :	Yes

Question Number : 61 Question Id : 4165299926 Question Type : MCQ Option Shuffling : Yes Display Question Number : Yes
Single Line Question Option : No Option Orientation : Vertical

Correct Marks : 4 Wrong Marks : 1

Let Z be the set of integers. If
 $A = \{x \in Z : 2(x+2)(x^2 - 5x + 6) = 1\}$ and
 $B = \{x \in Z : -3 < 2x - 1 < 9\}$, then the number
of subsets of the set $A \times B$, is :

Options :

41652939162. 2^{10}

41652939163. 2^{12}

41652939164. 2^{15}

41652939165. 2^{18}

Question Number : 61 Question Id : 4165299926 Question Type : MCQ Option Shuffling : Yes Display Question Number : Yes
Single Line Question Option : No Option Orientation : Vertical

Correct Marks : 4 Wrong Marks : 1

माना Z पूर्णाकों का समुच्चय है। यदि

$A = \{x \in Z : 2(x+2)(x^2 - 5x + 6) = 1\}$ तथा

$B = \{x \in Z : -3 < 2x - 1 < 9\}$, तो $A \times B$ के

उपसमुच्चयों की संख्या है :

Options :

41652939162. 2^{10}

41652939163. 2^{12}

41652939164. 2^{15}

41652939165. 2^{18}

Question Number : 62 Question Id : 4165299927 Question Type : MCQ Option Shuffling : Yes Display Question Number : Yes
Single Line Question Option : No Option Orientation : Vertical
Correct Marks : 4 Wrong Marks : 1

The number of integral values of m for which the quadratic expression, $(1 + 2m)x^2 - 2(1 + 3m)x + 4(1 + m)$, $x \in \mathbf{R}$, is always positive, is :

Options :

41652939166. 8

41652939167. 7

41652939168. 6

41652939169. 3

Question Number : 62 Question Id : 4165299927 Question Type : MCQ Option Shuffling : Yes Display Question Number : Yes
Single Line Question Option : No Option Orientation : Vertical
Correct Marks : 4 Wrong Marks : 1

m के उन पूर्णांक मानों, जिनके लिए द्विपद व्यंजक $(1 + 2m)x^2 - 2(1 + 3m)x + 4(1 + m)$, $x \in \mathbf{R}$, सदा धनात्मक है, की संख्या है :

Options :

41652939166. 8

41652939167. 7

41652939168. 6

41652939169. 3

Question Number : 63 Question Id : 4165299928 Question Type : MCQ Option Shuffling : Yes Display Question Number : Yes
Single Line Question Option : No Option Orientation : Vertical
Correct Marks : 4 Wrong Marks : 1

Let z_1 and z_2 be two complex numbers satisfying $|z_1| = 9$ and $|z_2 - 3 - 4i| = 4$. Then the minimum value of $|z_1 - z_2|$ is :

Options :

Download all NOTES and PAPERS at StudentSuvidha.com

41652939170. 0

41652939171. 1

41652939172. $\sqrt{2}$

41652939173. 2

Question Number : 63 Question Id : 4165299928 Question Type : MCQ Option Shuffling : Yes Display Question Number : Yes
Single Line Question Option : No Option Orientation : Vertical

Correct Marks : 4 Wrong Marks : 1

माना z_1 तथा z_2 दो सम्मिश्र संख्यायें हैं, जो $|z_1| = 9$
तथा $|z_2 - 3 - 4i| = 4$ को सन्तुष्ट करती है, तो $|z_1 - z_2|$
का न्यूनतम मान है :

Options :

41652939170. 0

41652939171. 1

41652939172. $\sqrt{2}$

41652939173. 2

Question Number : 64 Question Id : 4165299929 Question Type : MCQ Option Shuffling : Yes Display Question Number : Yes
Single Line Question Option : No Option Orientation : Vertical

Correct Marks : 4 Wrong Marks : 1

If $A = \begin{bmatrix} 1 & \sin\theta & 1 \\ -\sin\theta & 1 & \sin\theta \\ -1 & -\sin\theta & 1 \end{bmatrix}$; then for all

$\theta \in \left(\frac{3\pi}{4}, \frac{5\pi}{4}\right)$, $\det(A)$ lies in the interval :

Options :

41652939174. $\left(0, \frac{3}{2}\right]$

41652939175. $\left(1, \frac{5}{2}\right]$

41652939176. $\left(\frac{3}{2}, 3\right]$

$$\left[\frac{5}{2}, 4 \right)$$

41652939177.

Question Number : 64 Question Id : 4165299929 Question Type : MCQ Option Shuffling : Yes Display Question Number : Yes
Single Line Question Option : No Option Orientation : Vertical

Correct Marks : 4 Wrong Marks : 1

यदि $A = \begin{bmatrix} 1 & \sin \theta & 1 \\ -\sin \theta & 1 & \sin \theta \\ -1 & -\sin \theta & 1 \end{bmatrix}$; तो सभी

$\theta \in \left(\frac{3\pi}{4}, \frac{5\pi}{4} \right)$ के लिए, $\det(A)$ निम्न में से किस अंतराल में स्थित है?

Options :

41652939174. $\left(0, \frac{3}{2} \right]$

41652939175. $\left(1, \frac{5}{2} \right]$

41652939176. $\left(\frac{3}{2}, 3 \right]$

41652939177. $\left[\frac{5}{2}, 4 \right)$

Question Number : 65 Question Id : 4165299930 Question Type : MCQ Option Shuffling : Yes Display Question Number : Yes
Single Line Question Option : No Option Orientation : Vertical

Correct Marks : 4 Wrong Marks : 1

The set of all values of λ for which the system of linear equations

$$x - 2y - 2z = \lambda x$$

$$x + 2y + z = \lambda y$$

$$-x - y = \lambda z$$

has a non-trivial solution :

Options :

41652939178. is a singleton

41652939179. is an empty set

41652939180. contains exactly two elements

41652939181. contains more than two elements

Question Number : 65 Question Id : 4165299930 Question Type : MCQ Option Shuffling : Yes Display Question Number : Yes
Single Line Question Option : No Option Orientation : Vertical

Correct Marks : 4 Wrong Marks : 1

λ के उन सभी मानों, जिनके लिए रेखिक समीकरण
निकाय

$$x - 2y - 2z = \lambda x$$

$$x + 2y + z = \lambda y$$

$$-x - y = \lambda z$$

का एक अतुच्छ (non-trivial) हल है :

Options :

41652939178. का समुच्चय एकल है।

41652939179. का समुच्चय रिक्त है।

41652939180. के समुच्चय में मात्र दो अवयव हैं।

41652939181. के समुच्चय में दो से अधिक अवयव हैं।

Question Number : 66 Question Id : 4165299931 Question Type : MCQ Option Shuffling : Yes Display Question Number : Yes
Single Line Question Option : No Option Orientation : Vertical

Correct Marks : 4 Wrong Marks : 1

There are m men and two women participating in a chess tournament. Each participant plays two games with every other participant. If the number of games played by the men between themselves exceeds the number of games played between the men and the women by 84, then the value of m is :

Options :

41652939182. 7

41652939183. 9

41652939184. 11

41652939185. 12

Question Number : 66 Question Id : 4165299931 Question Type : MCQ Option Shuffling : Yes Display Question Number : Yes
Single Line Question Option : No Option Orientation : Vertical

Correct Marks : 4 Wrong Marks : 1

एक शतरंज प्रतियोगिता में m पुरुष तथा दो महिलाएं भाग ले रही हैं। प्रत्येक भागी (participant) दूसरे प्रत्येक भागी के साथ दो गेम (games) खेलता है। यदि पुरुषों के बीच आपस में खेले गये गेमों की संख्या, पुरुषों तथा महिलाओं के बीच खेले गये गेमों की संख्या से 84 अधिक हैं, तो m का मान है :

Options :

41652939182. 7

41652939183. 9

41652939184. 11

41652939185. 12

Question Number : 67 Question Id : 4165299932 Question Type : MCQ Option Shuffling : Yes Display Question Number : Yes
Single Line Question Option : No Option Orientation : Vertical

Correct Marks : 4 Wrong Marks : 1

The total number of irrational terms in the

binomial expansion of $\left(7^{1/5} - 3^{1/10}\right)^{60}$ is :

Options :

41652939186. 48

41652939187. 49

41652939188. 54

41652939189. 55

Question Number : 67 Question Id : 4165299932 Question Type : MCQ Option Shuffling : Yes Display Question Number : Yes
Single Line Question Option : No Option Orientation : Vertical

Correct Marks : 4 Wrong Marks : 1

$\left(7^{1/5} - 3^{1/10}\right)^{60}$ के द्विपद प्रसार में अपरिमेय पदों

की कुल संख्या है :

Options :

41652939186. 48

41652939187. 49

41652939188. 54

41652939189. 55

Question Number : 68 Question Id : 4165299933 Question Type : MCQ Option Shuffling : Yes Display Question Number : Yes
Single Line Question Option : No Option Orientation : Vertical

Correct Marks : 4 Wrong Marks : 1

If nC_4 , nC_5 and nC_6 are in A.P., then n can be :

Options :

41652939190. 9

41652939191. 11

41652939192. 12

41652939193. 14

Question Number : 68 Question Id : 4165299933 Question Type : MCQ Option Shuffling : Yes Display Question Number : Yes
Single Line Question Option : No Option Orientation : Vertical

Correct Marks : 4 Wrong Marks : 1

यदि nC_4 , nC_5 तथा nC_6 समान्तर श्रेणी में हैं, तो n हो सकता है :

Options :

41652939190. 9

41652939191. 11

41652939192. 12

41652939193. 14

Question Number : 69 Question Id : 4165299934 Question Type : MCQ Option Shuffling : Yes Display Question Number : Yes
Single Line Question Option : No Option Orientation : Vertical

Correct Marks : 4 Wrong Marks : 1

If the sum of the first 15 terms of the series

$$\left(\frac{3}{4}\right)^3 + \left(1\frac{1}{2}\right)^3 + \left(2\frac{1}{4}\right)^3 + 3^3 + \left(3\frac{3}{4}\right)^3 + \dots$$

is equal to 225 k, then k is equal to :

Options :

41652939194. 9

41652939195. 27

41652939196. 54

41652939197. 108

Question Number : 69 Question Id : 4165299934 Question Type : MCQ Option Shuffling : Yes Display Question Number : Yes
Single Line Question Option : No Option Orientation : Vertical

Correct Marks : 4 Wrong Marks : 1

यदि श्रेणी

$$\left(\frac{3}{4}\right)^3 + \left(1\frac{1}{2}\right)^3 + \left(2\frac{1}{4}\right)^3 + 3^3 + \left(3\frac{3}{4}\right)^3 + \dots$$

के प्रथम 15 पदों का योग $225k$ के बराबर है, तो k
बराबर है :

Options :

41652939194. 9

41652939195. 27

41652939196. 54

41652939197. 108

Question Number : 70 Question Id : 4165299935 Question Type : MCQ Option Shuffling : Yes Display Question Number : Yes
Single Line Question Option : No Option Orientation : Vertical

Correct Marks : 4 Wrong Marks : 1

$$\lim_{x \rightarrow 1^-} \frac{\sqrt{\pi} - \sqrt{2 \sin^{-1} x}}{\sqrt{1-x}} \text{ is equal to :}$$

Options :

41652939198. $\sqrt{\frac{2}{\pi}}$

41652939199. $\sqrt{\frac{\pi}{2}}$

41652939200. $\frac{1}{\sqrt{2\pi}}$

$$\sqrt{\pi}$$

41652939201.

Question Number : 70 Question Id : 4165299935 Question Type : MCQ Option Shuffling : Yes Display Question Number : Yes
Single Line Question Option : No Option Orientation : Vertical

Correct Marks : 4 Wrong Marks : 1

$$\lim_{x \rightarrow 1^-} \frac{\sqrt{\pi} - \sqrt{2 \sin^{-1} x}}{\sqrt{1-x}} \text{ बराबर है :}$$

Options :

$$\sqrt{\frac{2}{\pi}}$$

41652939198.

$$\sqrt{\frac{\pi}{2}}$$

41652939199.

$$\frac{1}{\sqrt{2\pi}}$$

41652939200.

$$\sqrt{\pi}$$

41652939201.

Question Number : 71 Question Id : 4165299936 Question Type : MCQ Option Shuffling : Yes Display Question Number : Yes
Single Line Question Option : No Option Orientation : Vertical

Correct Marks : 4 Wrong Marks : 1

Let f be a differentiable function such that $f(1) = 2$ and $f'(x) = f(x)$ for all $x \in \mathbb{R}$. If $h(x) = f(f(x))$, then $h'(1)$ is equal to :

Options :

41652939202. $2e^2$

41652939203. $4e$

41652939204. $2e$

41652939205. $4e^2$

Question Number : 71 Question Id : 4165299936 Question Type : MCQ Option Shuffling : Yes Display Question Number : Yes
Single Line Question Option : No Option Orientation : Vertical

Correct Marks : 4 Wrong Marks : 1

माना f एक अवकलनीय फलन इस प्रकार है कि $f(1) = 2$
तथा सभी $x \in \mathbb{R}$ के लिए $f'(x) = f(x)$. यदि
 $h(x) = f(f(x))$, तो $h'(1)$ बराबर है :

Options :

41652939202. $2e^2$

41652939203. $4e$

41652939204. $2e$

41652939205. $4e^2$

Question Number : 72 Question Id : 4165299937 Question Type : MCQ Option Shuffling : Yes Display Question Number : Yes
Single Line Question Option : No Option Orientation : Vertical

Correct Marks : 4 Wrong Marks : 1

The tangent to the curve $y = x^2 - 5x + 5$,
parallel to the line $2y = 4x + 1$, also passes
through the point :

Options :

41652939206. $\left(\frac{7}{2}, \frac{1}{4}\right)$

41652939207. $\left(\frac{1}{4}, \frac{7}{2}\right)$

41652939208. $\left(-\frac{1}{8}, 7\right)$

41652939209. $\left(\frac{1}{8}, -7\right)$

Question Number : 72 Question Id : 4165299937 Question Type : MCQ Option Shuffling : Yes Display Question Number : Yes
Single Line Question Option : No Option Orientation : Vertical

Correct Marks : 4 Wrong Marks : 1

वक्र $y = x^2 - 5x + 5$ की स्पर्श रेखा, जो रेखा
 $2y = 4x + 1$ के समान्तर है, निम्न में से किस बिन्दु से
होकर जाती है ?

Options :

$$\left(\frac{7}{2}, \frac{1}{4}\right)$$

41652939206.

$$\left(\frac{1}{4}, \frac{7}{2}\right)$$

41652939207.

$$\left(-\frac{1}{8}, 7\right)$$

41652939208.

$$\left(\frac{1}{8}, -7\right)$$

41652939209.

Question Number : 73 Question Id : 4165299938 Question Type : MCQ Option Shuffling : Yes Display Question Number : Yes
Single Line Question Option : No Option Orientation : Vertical

Correct Marks : 4 Wrong Marks : 1

If the function f given by

$f(x) = x^3 - 3(a-2)x^2 + 3ax + 7$, for some $a \in \mathbb{R}$
is increasing in $(0, 1]$ and decreasing in
 $[1, 5)$, then a root of the equation,

$$\frac{f(x) - 14}{(x-1)^2} = 0 \quad (x \neq 1) \text{ is :}$$

Options :

41652939210. -7

41652939211. 5

41652939212. 6

41652939213. 7

Question Number : 73 Question Id : 4165299938 Question Type : MCQ Option Shuffling : Yes Display Question Number : Yes
Single Line Question Option : No Option Orientation : Vertical

Correct Marks : 4 Wrong Marks : 1

यदि फलन $f(x) = x^3 - 3(a-2)x^2 + 3ax + 7$, किसी
 $a \in \mathbb{R}$ के लिए, $(0, 1]$ में वर्धमान है तथा $[1, 5)$ में ह्रासमान

है, तो समीकरण $\frac{f(x) - 14}{(x-1)^2} = 0 \quad (x \neq 1)$ का एक

हल है :

Options :

41652939210. -7

41652939211. 5

41652939212. 6

41652939213. 7

Question Number : 74 Question Id : 4165299939 Question Type : MCQ Option Shuffling : Yes Display Question Number : Yes
Single Line Question Option : No Option Orientation : Vertical

Correct Marks : 4 Wrong Marks : 1

The integral $\int \frac{3x^{13} + 2x^{11}}{(2x^4 + 3x^2 + 1)^4} dx$ is

equal to :

(where C is a constant of integration)

Options :

41652939214. $\frac{x^4}{6(2x^4 + 3x^2 + 1)^3} + C$

41652939215. $\frac{x^{12}}{6(2x^4 + 3x^2 + 1)^3} + C$

41652939216. $\frac{x^4}{(2x^4 + 3x^2 + 1)^3} + C$

41652939217. $\frac{x^{12}}{(2x^4 + 3x^2 + 1)^3} + C$

Question Number : 74 Question Id : 4165299939 Question Type : MCQ Option Shuffling : Yes Display Question Number : Yes
Single Line Question Option : No Option Orientation : Vertical

Correct Marks : 4 Wrong Marks : 1

समाकल $\int \frac{3x^{13} + 2x^{11}}{(2x^4 + 3x^2 + 1)^4} dx$ बराबर है :

(जहाँ C समाकलन का एक अचर है)

Options :

$$\frac{x^4}{6(2x^4 + 3x^2 + 1)^3} + C$$

41652939214.

$$\frac{x^{12}}{6(2x^4 + 3x^2 + 1)^3} + C$$

41652939215.

$$\frac{x^4}{(2x^4 + 3x^2 + 1)^3} + C$$

41652939216.

$$\frac{x^{12}}{(2x^4 + 3x^2 + 1)^3} + C$$

41652939217.

Question Number : 75 Question Id : 4165299940 Question Type : MCQ Option Shuffling : Yes Display Question Number : Yes
Single Line Question Option : No Option Orientation : Vertical

Correct Marks : 4 Wrong Marks : 1

The integral $\int_1^e \left\{ \left(\frac{x}{e} \right)^{2x} - \left(\frac{e}{x} \right)^x \right\} \log_e x \, dx$

is equal to :

Options :

$$\frac{3}{2} - \frac{1}{e} - \frac{1}{2e}$$

41652939218.

$$\frac{3}{2} - e - \frac{1}{2e^2}$$

41652939219.

$$-\frac{1}{2} + \frac{1}{e} - \frac{1}{2e^2}$$

41652939220.

$$\frac{1}{2} - e - \frac{1}{e^2}$$

41652939221.

Question Number : 75 Question Id : 4165299940 Question Type : MCQ Option Shuffling : Yes Display Question Number : Yes
Single Line Question Option : No Option Orientation : Vertical

Correct Marks : 4 Wrong Marks : 1

समाकल $\int_1^e \left\{ \left(\frac{x}{e} \right)^{2x} - \left(\frac{e}{x} \right)^x \right\} \log_e x \, dx$

बराबर है :

Options :

41652939218. $\frac{3}{2} - \frac{1}{e} - \frac{1}{2e^2}$

41652939219. $\frac{3}{2} - e - \frac{1}{2e^2}$

41652939220. $-\frac{1}{2} + \frac{1}{e} - \frac{1}{2e^2}$

41652939221. $\frac{1}{2} - e - \frac{1}{e^2}$

Question Number : 76 Question Id : 4165299941 Question Type : MCQ Option Shuffling : Yes Display Question Number : Yes Single Line Question Option : No Option Orientation : Vertical

Correct Marks : 4 Wrong Marks : 1

$\lim_{n \rightarrow \infty} \left(\frac{n}{n^2 + 1^2} + \frac{n}{n^2 + 2^2} + \frac{n}{n^2 + 3^2} + \dots + \frac{1}{5n} \right)$

is equal to :

Options :

41652939222. $\tan^{-1}(2)$

41652939223. $\tan^{-1}(3)$

41652939224. $\frac{\pi}{4}$

41652939225. $\frac{\pi}{2}$

Question Number : 76 Question Id : 4165299941 Question Type : MCQ Option Shuffling : Yes Display Question Number : Yes Single Line Question Option : No Option Orientation : Vertical

Correct Marks : 4 Wrong Marks : 1

$\lim_{n \rightarrow \infty} \left(\frac{n}{n^2 + 1^2} + \frac{n}{n^2 + 2^2} + \frac{n}{n^2 + 3^2} + \dots + \frac{1}{5n} \right)$

बराबर है :

Options :

41652939222. $\tan^{-1}(2)$

41652939223. $\tan^{-1}(3)$

41652939224. $\frac{\pi}{4}$

41652939225. $\frac{\pi}{2}$

Question Number : 77 Question Id : 4165299942 Question Type : MCQ Option Shuffling : Yes Display Question Number : Yes
Single Line Question Option : No Option Orientation : Vertical

Correct Marks : 4 Wrong Marks : 1

If a curve passes through the point $(1, -2)$ and has slope of the tangent at any point

(x, y) on it as $\frac{x^2 - 2y}{x}$, then the curve also

passes through the point :

Options :

41652939226. $(3, 0)$

41652939227. $(-1, 2)$

41652939228. $(-\sqrt{2}, 1)$

41652939229. $(\sqrt{3}, 0)$

Question Number : 77 Question Id : 4165299942 Question Type : MCQ Option Shuffling : Yes Display Question Number : Yes
Single Line Question Option : No Option Orientation : Vertical

Correct Marks : 4 Wrong Marks : 1

यदि एक वक्र बिन्दु $(1, -2)$ से होकर जाता है तथा इस पर किसी बिन्दु (x, y) पर स्पर्श रेखा का ढाल (slope)

$\frac{x^2 - 2y}{x}$ है, तो यह वक्र निम्न में से किस बिन्दु से

होकर जाता है?

Options :

41652939226. $(3, 0)$

41652939227. $(-1, 2)$

41652939228. $(-\sqrt{2}, 1)$

$$(\sqrt{3}, 0)$$

41652939229.

Question Number : 78 Question Id : 4165299943 Question Type : MCQ Option Shuffling : Yes Display Question Number : Yes
Single Line Question Option : No Option Orientation : Vertical

Correct Marks : 4 Wrong Marks : 1

If a straight line passing through the point $P(-3, 4)$ is such that its intercepted portion between the coordinate axes is bisected at P , then its equation is :

Options :

41652939230. $4x + 3y = 0$

41652939231. $x - y + 7 = 0$

41652939232. $3x - 4y + 25 = 0$

41652939233. $4x - 3y + 24 = 0$

Question Number : 78 Question Id : 4165299943 Question Type : MCQ Option Shuffling : Yes Display Question Number : Yes
Single Line Question Option : No Option Orientation : Vertical

Correct Marks : 4 Wrong Marks : 1

यदि बिन्दु $P(-3, 4)$ से होकर जाने वाली एक सरल रेखा इस प्रकार है कि इसका निर्देशांक अक्षों के बीच अंतःखण्डित भाग का मध्य बिन्दु P है, तो इसका समीकरण है :

Options :

41652939230. $4x + 3y = 0$

41652939231. $x - y + 7 = 0$

41652939232. $3x - 4y + 25 = 0$

41652939233. $4x - 3y + 24 = 0$

Question Number : 79 Question Id : 4165299944 Question Type : MCQ Option Shuffling : Yes Display Question Number : Yes
Single Line Question Option : No Option Orientation : Vertical

Correct Marks : 4 Wrong Marks : 1

If a circle of radius R passes through the origin O and intersects the coordinate axes at A and B , then the locus of the foot of perpendicular from O on AB is :

Options :

41652939234. $(x^2 + y^2)^3 = 4R^2x^2y^2$

41652939235. $(x^2 + y^2)^2 = 4R^2x^2y^2$

41652939236. $(x^2 + y^2)^2 = 4Rx^2y^2$

41652939237. $(x^2 + y^2)(x + y) = R^2xy$

Question Number : 79 Question Id : 4165299944 Question Type : MCQ Option Shuffling : Yes Display Question Number : Yes
Single Line Question Option : No Option Orientation : Vertical

Correct Marks : 4 Wrong Marks : 1

यदि R त्रिज्या का एक वृत्त मूल बिन्दु O से होकर जाता है तथा निर्देशांक अक्षों को A और B पर काटता है, तो O से रेखा AB पर डाले गये लम्ब के पाद का बिन्दुपथ है :

Options :

41652939234. $(x^2 + y^2)^3 = 4R^2x^2y^2$

41652939235. $(x^2 + y^2)^2 = 4R^2x^2y^2$

41652939236. $(x^2 + y^2)^2 = 4Rx^2y^2$

41652939237. $(x^2 + y^2)(x + y) = R^2xy$

Question Number : 80 Question Id : 4165299945 Question Type : MCQ Option Shuffling : Yes Display Question Number : Yes
Single Line Question Option : No Option Orientation : Vertical

Correct Marks : 4 Wrong Marks : 1

The equation of a tangent to the parabola, $x^2 = 8y$, which makes an angle θ with the positive direction of x -axis, is :

Options :

41652939238. $y = x \tan\theta - 2 \cot\theta$

41652939239. $x = y \cot\theta + 2 \tan\theta$

41652939240. $x = y \cot\theta - 2 \tan\theta$

41652939241. $y = x \tan\theta + 2 \cot\theta$

Question Number : 80 Question Id : 4165299945 Question Type : MCQ Option Shuffling : Yes Display Question Number : Yes
Single Line Question Option : No Option Orientation : Vertical

Correct Marks : 4 Wrong Marks : 1

परवलय $x^2 = 8y$ पर एक स्पर्श रेखा, जो x -अक्ष की धनात्मक दिशा के साथ कोण θ बनाती है, का समीकरण है :

Options :

41652939238. $y = x \tan\theta - 2 \cot\theta$

41652939239. $x = y \cot\theta + 2 \tan\theta$

41652939240. $x = y \cot\theta - 2 \tan\theta$

41652939241. $y = x \tan\theta + 2 \cot\theta$

Question Number : 81 Question Id : 4165299946 Question Type : MCQ Option Shuffling : Yes Display Question Number : Yes Single Line Question Option : No Option Orientation : Vertical

Correct Marks : 4 Wrong Marks : 1

Let S and S' be the foci of an ellipse and B be any one of the extremities of its minor axis. If $\Delta S'BS$ is a right angled triangle with right angle at B and area $(\Delta S'BS) = 8$ sq. units, then the length of a latus rectum of the ellipse is :

Options :

41652939242. 2

41652939243. $2\sqrt{2}$

41652939244. $4\sqrt{2}$

41652939245. 4

Question Number : 81 Question Id : 4165299946 Question Type : MCQ Option Shuffling : Yes Display Question Number : Yes Single Line Question Option : No Option Orientation : Vertical

Correct Marks : 4 Wrong Marks : 1

माना एक दीर्घवृत्त की नाभियाँ S तथा S' हैं तथा इसके लघु अक्ष का कोई एक शीर्ष B है। यदि $\Delta S'BS$ एक समकोण त्रिभुज है जिसका समकोण B पर है तथा $\Delta S'BS$ का क्षेत्रफल 8 वर्ग इकाई है, तो दीर्घवृत्त की एक नाभिलम्ब जीवा की लम्बाई है :

Options :

41652939242. 2

41652939243. $2\sqrt{2}$

41652939244. $4\sqrt{2}$

41652939245. 4

Question Number : 82 Question Id : 4165299947 Question Type : MCQ Option Shuffling : Yes Display Question Number : Yes
Single Line Question Option : No Option Orientation : Vertical

Correct Marks : 4 Wrong Marks : 1

If an angle between the line,

$$\frac{x+1}{2} = \frac{y-2}{1} = \frac{z-3}{-2} \text{ and the plane,}$$

$x - 2y - kz = 3$ is $\cos^{-1}\left(\frac{2\sqrt{2}}{3}\right)$, then a value

of k is :

Options :

41652939246. $\sqrt{\frac{5}{3}}$

41652939247. $\sqrt{\frac{3}{5}}$

41652939248. $-\frac{3}{5}$

41652939249. $-\frac{5}{3}$

Question Number : 82 Question Id : 4165299947 Question Type : MCQ Option Shuffling : Yes Display Question Number : Yes
Single Line Question Option : No Option Orientation : Vertical

Correct Marks : 4 Wrong Marks : 1

यदि रेखा $\frac{x+1}{2} = \frac{y-2}{1} = \frac{z-3}{-2}$ तथा समतल

$x - 2y - kz = 3$ के बीच का कोण $\cos^{-1}\left(\frac{2\sqrt{2}}{3}\right)$

है, तो k का एक मान है :

Options :

41652939246. $\sqrt{\frac{5}{3}}$

41652939247. $\sqrt{\frac{3}{5}}$

41652939248. $-\frac{3}{5}$

41652939249. $-\frac{5}{3}$

Question Number : 83 Question Id : 4165299948 Question Type : MCQ Option Shuffling : Yes Display Question Number : Yes
Single Line Question Option : No Option Orientation : Vertical

Correct Marks : 4 Wrong Marks : 1

Let S be the set of all real values of λ such that a plane passing through the points $(-\lambda^2, 1, 1)$, $(1, -\lambda^2, 1)$ and $(1, 1, -\lambda^2)$ also passes through the point $(-1, -1, 1)$. Then S is equal to :

Options :

41652939250. $\{\sqrt{3}\}$

41652939251. $\{1, -1\}$

41652939252. $\{3, -3\}$

41652939253. $\{\sqrt{3}, -\sqrt{3}\}$

Question Number : 83 Question Id : 4165299948 Question Type : MCQ Option Shuffling : Yes Display Question Number : Yes
Single Line Question Option : No Option Orientation : Vertical

Correct Marks : 4 Wrong Marks : 1

यदि λ के उन सभी वास्तविक मानों, जिनके लिए बिन्दुओं $(-\lambda^2, 1, 1)$, $(1, -\lambda^2, 1)$ तथा $(1, 1, -\lambda^2)$ से होकर जाने वाला एक समतल, बिन्दु $(-1, -1, 1)$ से भी होकर जाता है, का समुच्चय S है, तो S बराबर है :

Options :

41652939250. $\{\sqrt{3}\}$

41652939251. $\{1, -1\}$

41652939252. $\{3, -3\}$

41652939253.

$$\{\sqrt{3}, -\sqrt{3}\}$$

Question Number : 84 Question Id : 4165299949 Question Type : MCQ Option Shuffling : Yes Display Question Number : Yes
Single Line Question Option : No Option Orientation : Vertical

Correct Marks : 4 Wrong Marks : 1

Let \vec{a} , \vec{b} and \vec{c} be three unit vectors, out of which vectors \vec{b} and \vec{c} are non-parallel.

If α and β are the angles which vector \vec{a} makes with vectors \vec{b} and \vec{c} respectively

and $\vec{a} \times (\vec{b} \times \vec{c}) = \frac{1}{2} \vec{b}$, then $|\alpha - \beta|$ is

equal to :

Options :

41652939254. 60°

41652939255. 45°

41652939256. 30°

41652939257. 90°

Question Number : 84 Question Id : 4165299949 Question Type : MCQ Option Shuffling : Yes Display Question Number : Yes
Single Line Question Option : No Option Orientation : Vertical

Correct Marks : 4 Wrong Marks : 1

माना \vec{a} , \vec{b} तथा \vec{c} तीन एकक सदिश हैं, जिनमें से सदिश \vec{b} तथा \vec{c} असमान्तर हैं। यदि सदिश \vec{a} ,

सदिशों \vec{b} तथा \vec{c} से क्रमशः कोण α तथा β बनाता है

और $\vec{a} \times (\vec{b} \times \vec{c}) = \frac{1}{2} \vec{b}$, तो $|\alpha - \beta|$ बराबर

है :

Options :

41652939254. 60°

41652939255. 45°

41652939256. 30°

41652939257. 90°

Question Number : 85 Question Id : 4165299950 Question Type : MCQ Option Shuffling : Yes Display Question Number : Yes
Single Line Question Option : No Option Orientation : Vertical

Correct Marks : 4 Wrong Marks : 1

The mean and the variance of five observations are 4 and 5.20, respectively. If three of the observations are 3, 4 and 4 ; then the absolute value of the difference of the other two observations, is :

Options :

41652939258. 1

41652939259. 3

41652939260. 5

41652939261. 7

Question Number : 85 Question Id : 4165299950 Question Type : MCQ Option Shuffling : Yes Display Question Number : Yes
Single Line Question Option : No Option Orientation : Vertical

Correct Marks : 4 Wrong Marks : 1

पाँच प्रेक्षणों का माध्य तथा प्रसरण क्रमशः 4 तथा 5.20 हैं। यदि इन प्रेक्षणों में से तीन 3, 4 तथा 4 हैं, तो अन्य दो प्रेक्षणों के अन्तर का निरपेक्ष (absolute) मान है :

Options :

41652939258. 1

41652939259. 3

41652939260. 5

41652939261. 7

Question Number : 86 Question Id : 4165299951 Question Type : MCQ Option Shuffling : Yes Display Question Number : Yes
Single Line Question Option : No Option Orientation : Vertical

Correct Marks : 4 Wrong Marks : 1

In a class of 60 students, 40 opted for NCC, 30 opted for NSS and 20 opted for both NCC and NSS. If one of these students is selected at random, then the probability that the student selected has opted neither for NCC nor for NSS is :

Options :

Download all NOTES and PAPERS at StudentSuvidha.com

41652939262. $\frac{1}{6}$

41652939263. $\frac{2}{3}$

41652939264. $\frac{5}{6}$

41652939265. $\frac{1}{3}$

Question Number : 86 Question Id : 4165299951 Question Type : MCQ Option Shuffling : Yes Display Question Number : Yes
Single Line Question Option : No Option Orientation : Vertical
Correct Marks : 4 Wrong Marks : 1

60 छात्रों की एक कक्षा में, 40 ने NCC ली, 30 ने NSS ली तथा 20 ने NCC और NSS दोनों लीं। यदि इनमें से एक छात्र यादृच्छिक चुना गया है, तो चुने हुए छात्र के न तो NCC, न ही NSS लेने की प्रायिकता है :

Options :

41652939262. $\frac{1}{6}$

41652939263. $\frac{2}{3}$

41652939264. $\frac{5}{6}$

41652939265. $\frac{1}{3}$

Question Number : 87 Question Id : 4165299952 Question Type : MCQ Option Shuffling : Yes Display Question Number : Yes
Single Line Question Option : No Option Orientation : Vertical
Correct Marks : 4 Wrong Marks : 1

In a game, a man wins Rs. 100 if he gets 5 or 6 on a throw of a fair die and loses Rs. 50 for getting any other number on the die. If he decides to throw the die either till he gets a five or a six or to a maximum of three throws, then his expected gain/loss (in rupees) is :

Options : [Download all NOTES and PAPERS at StudentSuvidha.com](http://StudentSuvidha.com)

41652939266. $\frac{400}{9}$ loss

41652939267. $\frac{400}{3}$ loss

41652939268. $\frac{400}{3}$ gain

41652939269. 0

Question Number : 87 Question Id : 4165299952 Question Type : MCQ Option Shuffling : Yes Display Question Number : Yes
Single Line Question Option : No Option Orientation : Vertical

Correct Marks : 4 Wrong Marks : 1

एक खेल में एक अनभिन्नत पासा फेंकने पर 5 या 6 आने पर एक व्यक्ति 100 रु. जीतता है तथा पासे पर कोई अन्य संख्या आने पर 50 रु. हारता है। यदि वह यह तय करता है कि वह या तब तक पासा फेंकेगा जब तक 5 या 6 न आ जाए अथवा अधिक से अधिक तीन बार पासा फेंकेगा, तो उसकी संभावित लाभ/हानि (रुपयों में) है :

Options :

41652939266. $\frac{400}{9}$ हानि

41652939267. $\frac{400}{3}$ हानि

41652939268. $\frac{400}{3}$ लाभ

41652939269. 0

Question Number : 88 Question Id : 4165299953 Question Type : MCQ Option Shuffling : Yes Display Question Number : Yes
Single Line Question Option : No Option Orientation : Vertical

Correct Marks : 4 Wrong Marks : 1

If $\sin^4 \alpha + 4 \cos^4 \beta + 2 = 4\sqrt{2} \sin \alpha \cos \beta$;
 $\alpha, \beta \in [0, \pi]$, then $\cos(\alpha + \beta) - \cos(\alpha - \beta)$ is equal to :

Options :

41652939270. $\sqrt{2}$

41652939271. $-\sqrt{2}$

41652939272. 0

41652939273. -1

Question Number : 88 Question Id : 4165299953 Question Type : MCQ Option Shuffling : Yes Display Question Number : Yes
Single Line Question Option : No Option Orientation : Vertical

Correct Marks : 4 Wrong Marks : 1

यदि

$$\sin^4 \alpha + 4 \cos^4 \beta + 2 = 4\sqrt{2} \sin \alpha \cos \beta, \alpha,$$

$\beta \in [0, \pi]$ तो $\cos(\alpha + \beta) - \cos(\alpha - \beta)$ बराबर

है :

Options :

41652939270. $\sqrt{2}$

41652939271. $-\sqrt{2}$

41652939272. 0

41652939273. -1

Question Number : 89 Question Id : 4165299954 Question Type : MCQ Option Shuffling : Yes Display Question Number : Yes
Single Line Question Option : No Option Orientation : Vertical

Correct Marks : 4 Wrong Marks : 1

If the angle of elevation of a cloud from a point P which is 25 m above a lake be 30° and the angle of depression of reflection of the cloud in the lake from P be 60° , then the height of the cloud (in meters) from the surface of the lake is :

Options :

41652939274. 60

41652939275. 50

41652939276. 45

41652939277. 42

Question Number : 89 Question Id : 4165299954 Question Type : MCQ Option Shuffling : Yes Display Question Number : Yes
Single Line Question Option : No Option Orientation : Vertical

Correct Marks : 4 Wrong Marks : 1

एक झील से 25 m ऊपर एक बिन्दु P से एक बादल का उन्नयन कोण 30° है तथा P से झील में बादल के प्रतिबिम्ब का अवनमन कोण 60° है, तो झील की सतह से बादल की ऊँचाई (मीटर में) है :

Options :

41652939274. 60

41652939275. 50

41652939276. 45

41652939277. 42

Question Number : 90 Question Id : 4165299955 Question Type : MCQ Option Shuffling : Yes Display Question Number : Yes Single Line Question Option : No Option Orientation : Vertical

Correct Marks : 4 Wrong Marks : 1

The expression $\sim(\sim p \rightarrow q)$ is logically equivalent to :

Options :

41652939278. $P \wedge q$

41652939279. $P \wedge \sim q$

41652939280. $\sim P \wedge q$

41652939281. $\sim P \wedge \sim q$

Question Number : 90 Question Id : 4165299955 Question Type : MCQ Option Shuffling : Yes Display Question Number : Yes Single Line Question Option : No Option Orientation : Vertical

Correct Marks : 4 Wrong Marks : 1

व्यंजक $\sim(\sim p \rightarrow q)$ निम्न में से किसके तर्क संगत तुल्य है?

Options :

41652939278. $P \wedge q$

41652939279. $P \wedge \sim q$

41652939280. $\sim P \wedge q$

41652939281. $\sim P \wedge \sim q$